



UNIVERSAL

Acoustic & Emission Technologies

Industrial Fan Silencers

Technical Literature

AFS Series

∴ Absorptive/Reactive
Combination Type Silencer Page 3

Acousti-Vane Series

∴ Absorptive/Parallel Baffle Type Rectangular Silencer

- ∴ LP Acousti-Vane Page 4–5
- ∴ MP Acousti-Vane Page 4–5
- ∴ HP Acousti-Vane Page 4–5

Acousti-Tube Series

∴ Absorptive/Tubular Flow
Type Rectangular Silencer Page 6

*Universal AET retains the right to update this technical sheet without notice.
Please contact your Universal representative to verify the timelines of this technical literature sheet.*



General Information

Industrial Fan Silencers

Primary air fans, forced draft fans and induced draft fans generally require some form of acoustical treatment. Most applications require inlet and/or outlet silencers to meet OSHA and other noise requirements. For continuous exposure, a maximum of 90 dBA is generally specified to avoid hearing damage. When conversation near the fan is desired, levels of 80 dBA and less are often needed.

Universal designs and manufactures a complete line of silencers for application on all fan types. Computer enhanced technology developed for fan, turbine, and other air moving equipment enables Universal to offer a cost-effective solution for every fan silencing application.

Each of the four designs in this section has unique advantages over the others, depending upon the application, pressure drop and space utilization. This catalog covers standard models and sizes and provides basic information to evaluate the merits of the individual designs for your application. Special configurations, materials, higher temperatures, and sizes are available upon request.

AFS Series Absorptive/Reactive Silencer

The AFS series fan silencer combines a reactive and absorptive chamber design that both reflects acoustic energy and dissipates it with absorptive pack material. Constructed from plate and sheet steel in an all-welded, straight-through flow path design, the AFS series is suitable for most applications on the inlet and discharge of centrifugal or axial blowers, especially when low pressure drop is required. The standard AFS silencer is suitable for temperatures up to 325°F.

Acousti-Vane Absorptive/Parallel Baffle Silencer

The Acousti-Vane silencer comes in standard cross-sections and lengths that cover a wide range of applications and provide economical solutions to a broad range of noise conditions. Standard units can be adapted for use in non-standard or application-specific configurations.

The Acousti-Vane is available in three standard models:

LP

The low-pressure drop Acousti-Vane has lower pressure drop than the other two models and is the most economical of the three. The LP is the silencer of choice when pressure drop is critical and a relatively small amount of noise attenuation is needed.

MP

The moderate pressure-drop Acousti-Vane offers greater acoustic performance than the LP at a slightly higher pressure drop. The MP models meets most noise attenuation specifications.

HP

The high-performance Acousti-Vane provides maximum acoustic performance at a higher pressure drop than the LP or MP. The HP models is ideal for the most demanding acoustical environment.

The steel frame of the Acousti-Vane silencers has high sound transmission loss. The standard shell finish includes solvent-cleaning by SSPC-SP-1, shop coat primer inside and outside, and a blue enamel coating outside. The paint system withstands internal gas and skin temperatures up to 200°F. Optional paint systems are available.

Acousti-Tube Absorptive/Tubular Flow Silencer

The modular, compact, lightweight Acousti-Tube silencer knocks out high-frequency noise while minimizing pressure drop.

The Acousti-Tube silencer is available in standard cross-sections and lengths, which cover a wide range of product applications and are economical solutions to noise problems. The silencer's modular design allows customization for non-standard configurations without any loss of acoustic performance or increased pressure loss.

Composite materials are used in the flowpath to reduce corrosion and maintenance. The lightweight, easy-to-handle design reduces shipping cost and installation time. The Acousti-Tube modules are factory-assembled in a high-transmission-loss steel frame. The frame has a standard high-performance, two coat paint system on interior and exterior surfaces suitable for outdoor installations.



Sizing Information

Industrial Fan Silencers

In order to properly size a fan silencer, the flow area through it must be sufficient to accommodate the maximum flow without imposing excessive pressure drop. The following instructions enable you to select the proper silencer size and determine actual pressure drop. These instructions assume flowing gas is air. For other gases, density, and other corrections, contact Universal Silencer for assistance.

Data required:

- air flow rate (actual CFM)
- temperature (°F)
- pressure (psig)
- maximum pressure drop (inches of water)

1 Determine the maximum velocity to achieve the required pressure drop.

$$V = 4005 \sqrt{\left(\frac{\Delta P}{c}\right) \left(\frac{14.7}{P + 14.7}\right) \left(\frac{T + 460}{530}\right)}$$

V = air or gas velocity, ft/min
(see Note 1)

ΔP = maximum pressure drop,
inches of water

c = silencer pressure drop coefficient (see page 5.5)

T = air temperature, °F (see Note 2)

P = operating pressure, psig
(if at atmospheric pressure, pressure ratio is unity and may be omitted from equation; if P exceeds 15 psig, contact Universal Silencer for recommendations)

2 Determine flow area required.

$$A = \frac{Q}{V}$$

A required = flow area required, ft²

Q = air flow rate (actual CFM)

For reference, if SCFM is given rather than ACFM, then convert using the following equation.

$$\text{Actual CFM} = (\text{Standard CFM}) \left(\frac{14.7}{P + 14.7}\right) \left(\frac{T + 460}{530}\right)$$

3 From Table 1 or the tables on page 5.5 select a size with a flow area equal to or greater than that calculated in step 2.

4 Determine the actual gas velocity in feet per minute.

$$V_{\text{actual}} = \frac{Q}{A}$$

A = flow area of size of silencer chosen, ft²

5 Determine actual pressure drop in inches of water.

$$\Delta P = c \left(\frac{V_{\text{actual}}}{4005}\right)^2 \left(\frac{530}{T + 460}\right) \left(\frac{P + 14.7}{14.7}\right)$$

1 Conversion—Pipe Diameter from Flow Area

Flow Area (ft ²)	Diameter (in)
0.087	4
0.136	5
0.196	6
0.349	8
0.550	10
0.790	12
1.070	14
1.400	16
1.800	18
2.200	20
2.600	22
3.100	24
3.700	26
4.300	28
4.900	30
5.600	32
6.300	34
7.100	36
7.900	38
8.700	40
9.600	42
10.600	44
11.500	46
12.600	48
15.900	54
19.600	60

Notes

- 1 Since self noise and aerodynamic noise generation increase with velocity, absorptive silencers are usually sized for 4,000–8,000 ft/min. In no case should the velocity exceed 15,000 ft/min, regardless of pressure drop allowed.
- 2 Typical attenuation curves indicate the characteristics of the silencer series and are neither a minimum nor a guarantee for an individual silencer. Individual silencer performance can be affected by sound source characteristics including pure tones, flow velocity, adjacent piping, and temperature.



AFS Series

Combination Type Silencer

Typical Attenuation Curve

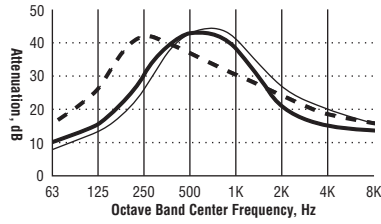

— 6" pipe size
 — 12" pipe size
 - - - 24" pipe size

Note

AFS series standard paint and acoustical packing are suitable for 325°F.

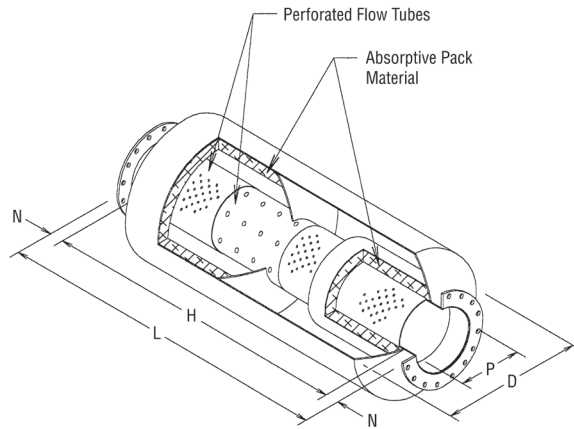

Features

- straight-through flow path
- combination reactive and absorptive design for best mid-frequency attenuation
- low-pressure drop
- pressure drop coefficient, $c = 0.6$ for pipe sizes < 24" and $c = 1.0$ for 24" and larger
- 124/150# ANSI drilled plate flanges
- all-welded mild steel construction
- primer-coated exterior

Common Applications

- centrifugal blowers inlet and discharge
- axial blowers inlet and discharge
- industrial fans inlet and discharge
- centrifugal compressors inlet
- small reciprocating compressors

Combination Type Silencer

Model	Part	P	D	L	N	H	Weight
AFS-4	61-104-AA	4	12	34	3	28	60
AFS-5	61-105-AA	5	14	40.5	3	34.5	80
AFS-6	61-106-AA	6	16	47	3	41	135
AFS-8	61-108-AA	8	20	60.5	3.5	53.5	220
AFS-10	61-110-AA	10	24	67.5	3.5	60.5	380
AFS-12	61-112-AA	12	28	74.5	3.5	67.5	500
AFS-14	61-114-AA	14	36	89	3.5	82	980
AFS-16	61-116-AA	16	36	100.5	3.5	93.5	1,150
AFS-18	61-118-AA	18	42	108	3.5	101	1,400
AFS-20	61-120-AA	20	48	124	4.5	115	1,800
AFS-22	61-122-AA	22	48	129	4.5	120	1,950
AFS-24	61-124-AA	24	54	143	4.5	134	2,450
AFS-26	61-126-AA	26	60	157	4.5	148	3,670
AFS-28	61-128-AA	28	60	168.5	4.5	159.5	4,100
AFS-30	61-130-AA	30	66	182	4.5	173	4,825
AFS-32	61-132-AA	32	66	187.5	4.5	178.5	5,100
AFS-34	61-134-AA	34	66	193	4.5	184	5,400
AFS-36	61-136-AA	36	72	207	4.5	198	6,400
AFS-42	61-142-AA	42	84	220	6	208	9,500
AFS-48	61-148-AA	48	96	272	6	260	15,000



The Acousti-Vane silencer is designed as a stand-alone silencer or in series with USI's Acousti-Tube silencer. The superior noise attenuation of the Acousti-Vane, combined with the superior high-frequency performance of the Acousti-Tube, provides excellent noise control over a broad spectrum.

Acousti-Vane

Absorptive Parallel Baffle Type Rectangular Silencers

The Acousti-Vane silencer comes in standard cross-sections and lengths that cover a wide range of applications and provide economical solutions to a broad range of noise conditions. Standard units can be adapted for use in non-standard or application-specific configurations. The Acousti-Vane is available in three standard models:

LP

The *low-pressure drop* Acousti-Vane has the lowest pressure drop and is the most economical of the three.

MP

The *moderate-pressure drop* unit offers greater acoustic performance than the LP at a slightly higher pressure drop and meets most noise attenuation specifications.

HP

The *high-performance* Acousti-Vane provides the maximum acoustic performance. The HP model is ideal for the most demanding acoustical environment.

The steel frame for Acousti-Vane silencers has high sound transmission loss. The paint system withstands internal gas temperatures and skin temperatures up to 200°F. Optional paint systems are available.

How Do I Choose?

Three parameters are needed to select the correct silencer: (1) required acoustic insertion loss, (2) allowable pressure loss, and (3) the flow in actual cubic feet per minute (ACFM) of your equipment.

Follow these steps to find the silencer that is most appropriate for your application.

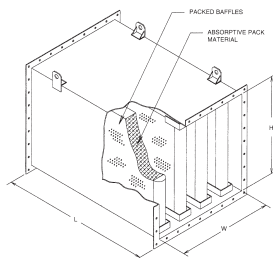

- 1 Determine the required dynamic insertion loss by octave band** for your equipment and select the minimum silencer length that gives the required loss for each model.
- 2 Determine the allowable pressure drop and flow in ACFM for your application.** To find the pressure drop for gas temperatures other than 60°F, multiply the selected value by $[520 / (\text{actual gas temperature } ^\circ\text{F} + 460)]$.
- 3 Choose the Acousti-Vane model for your application.** From the three graphs on page 5, choose the one that has the allowable pressure drop on the Y-axis. Read straight across until the line meets the pressure drop curve. The corresponding X-axis value is the maximum face velocity that will maintain the pressure drop requirement.
- 4 Divide the ACFM by the required face velocity** to find the minimum silencer cross-section that would give the required pressure drop.

Face velocity is defined as the flow rate in ACFM divided by the silencer face area in square feet ($W \times H$).
- 5 Select the silencer** from the tables on page 5.5. Replace L in the part number with the length of silencer you found in step 2. Specify whether the silencer is an LP, MP, or HP model. The pressure drop will be equal to or slightly below the allowable pressure drop you selected. For special applications that require minimum pressure drop and demanding acoustic specifications, contact Universal.

Acousti-Vane dimensions. The silencer comes in standard cross-sectional dimensions and standard flange patterns. Flange patterns also can be designed to match your specifications. Silencers may be applied at temperatures that range between -20°F and 200°F . For standard flange patterns, silencer weights, and other details, request Technical Bulletin 94-1327.

Example Case: Acousti-Vane Selection for a Gas Turbine Inlet

- 1** The insertion loss needed to attenuate noise is determined to be 4, 7, 12, 20, 20, 18, 18, 14, 11 in the octave band center frequencies 31.5 Hz–8 kHz.
- 2** Tables 1–3 on page 5.5 show that a **12-ft LP, 9-ft MP or a 5-ft HP** would satisfy the requirements.
- 3** For this application, the allowable pressure drop is 0.25 inches of water. Which eliminates the HP model (see graph to the right of the table). For purposes of example, the flow in ACFM is assumed to be 30,000.
- 4** The graphs on page 5 show that the maximum face velocity to achieve 0.25 inches of water is 2,000 ft/min for the 12-ft LP and 1,500 ft/min for the 9-ft MP.
- 5** Divide the flow in ACFM by the required face velocity for each silencer:

$$\text{LP} = 30,000 / 2,000 = 15 \text{ ft}^2$$

$$\text{MP} = 30,000 / 1,500 = 20 \text{ ft}^2$$
- 6** In Table 4 on page 5, find the silencer size that is equal to or greater than 15 ft^2 for the LP model and 20 ft^2 for the MP. In this example, the 4×4 LP (at 16 ft^2 face velocity) and 4×6 MP (at 24 ft^2) meet your specifications, so you choose between:

$$\text{AV} - 4 \times 4 - 12 - \text{LP}$$

or

$$\text{AV} - 4 \times 6 - 9 - \text{MP}$$



1 LP (low pressure drop) Models

Silencer Length (ft)	Octave Bands (Hz)								
	31.5	63	125	250	500	1K	2K	4K	8K
3	1	2	4	5	7	5	3	2	1
4	1	3	5	9	9	8	4	4	2
5	2	4	6	10	11	10	7	5	2
6	2	4	7	13	13	12	9	6	4
7	2	5	8	15	15	12	11	7	5
8	3	5	8	16	18	14	13	9	7
9	3	6	9	18	21	16	15	11	9
10	3	6	10	20	24	20	18	14	11
11	4	7	11	22	26	20	18	14	11
12	4	7	12	24	28	20	18	14	11

- 12 ft. Acousti-Vane
- ▲ 9 ft. Acousti-Vane
- 6 ft. Acousti-Vane
- ◆ 3 ft. Acousti-Vane

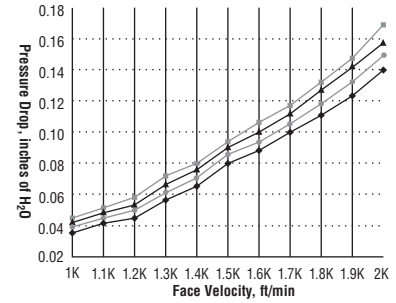

2 MP (moderate pressure drop) Models

Silencer Length (ft)	Octave Bands (Hz)								
	31.5	63	125	250	500	1K	2K	4K	8K
3	3	4	7	10	12	13	11	9	5
4	3	4	8	12	16	16	13	11	7
5	3	5	9	15	20	20	15	12	8
6	3	5	9	18	25	22	18	13	9
7	4	6	10	20	27	24	21	14	9
8	4	6	10	22	29	27	24	15	10
9	5	7	12	24	30	29	26	16	12
10	5	7	14	25	32	32	28	18	14
11	6	8	15	26	34	32	28	18	14
12	6	8	15	28	36	32	28	18	14

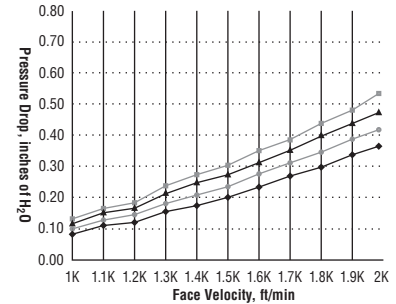

3 HP (high performance) Models

Silencer Length (ft)	Octave Bands (Hz)								
	31.5	63	125	250	500	1K	2K	4K	8K
3	3	5	9	13	15	16	16	12	7
4	3	6	10	16	18	20	20	14	10
5	4	7	12	21	22	23	24	16	12
6	4	8	14	23	26	27	27	19	14
7	5	8	15	25	30	31	31	21	16
8	5	9	16	27	33	36	33	24	18
9	5	9	17	29	36	41	36	27	20
10	6	10	19	31	39	46	39	30	22
11	6	10	19	33	42	47	42	30	23
12	7	11	20	35	45	48	45	30	24

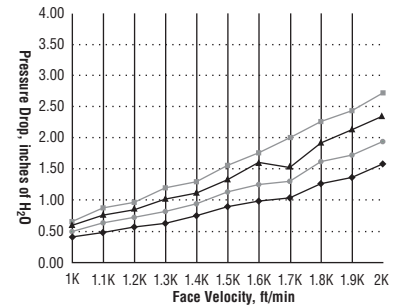

Notes: Dynamic insertion loss in dB for face velocities <1500 ft/min, and pressure drop for gas temperatures of 60 °F. To find the pressure drop for gas temperatures other than 60°F, multiply the selected value by $[520/(\text{actual gas temperature } ^\circ\text{F} + 460)]$. Contact Universal for more information about face velocities >2000 ft/min.

4 Acousti-Vane Part Numbers and Face Areas

Part Number (AV-H × W-model)	Face Area (ft ²)
AV-2 × 2-L-m	4
AV-2 × 3-L-m	6
AV-2 × 4-L-m	8
AV-3 × 4-L-m	12
AV-4 × 4-L-m	16
AV-4 × 6-L-m	24
AV-5 × 6-L-m	30
AV-6 × 6-L-m	36
AV-6 × 8-L-m	48
AV-7.5 × 7.5-L-m	56
AV-8 × 8-L-m	64

Acousti-Tube

Absorptive Tubular Flow Type Rectangular Silencers

The modular, compact, lightweight Acousti-Tube silencer knocks out high-frequency noise while minimizing pressure drop.

The Acousti-Tube silencer comes in standard cross-sections and lengths, which cover a wide range of applications and are economical solutions to industrial fan noise problems. The silencer's modular design enables customization for non-standard configurations without any loss of acoustic performance or increased pressure loss.

Composite materials are used in the flowpath to reduce corrosion and maintenance.

The lightweight, easy-to-handle design reduces shipping cost and installation time. The Acousti-Tube modules are factory-assembled in a high-transmission-loss steel frame. The frame has a standard high-performance, two-coat paint system on interior and exterior surfaces suitable for outdoor installations.

Acousti-Tube silencers operate optimally at temperatures between -20°F and 200°F.

How Do I Choose?

As with the Acousti-Vane, three parameters are needed to select the correct Acousti-Tube silencer: (1) required acoustic insertion loss, (2) allowable pressure loss, and (3) the flow in actual cubic feet per minute (ACFM) for your equipment.

Follow these steps to choose the appropriate silencer:

- Determine the required dynamic insertion loss by octave band for your equipment.** Use Table 1 to select the minimum silencer length that gives the required octave band insertion loss.
- Determine the allowable pressure drop and ACFM for your application.** In Figure 1, find the Y-axis value for the allowable pressure drop. Read straight across the graph to the pressure drop curve. The corresponding X-axis value is the maximum face velocity that will maintain the pressure drop requirement.
- Divide the ACFM by the required face velocity** to find the minimum cross-section that gives the required pressure drop. Face velocity is defined as the flow rate in ACFM divided by the silencer face area in square feet ($W \times H$).
- Select the silencer model** from Table 2. Replace L in the model number with the length of silencer you found in step 2. The part number for ordering will be the prefix 07-, the dimensions of the silencer, and the suffix -AA. So a 2 x 2 x 4 silencer would have a part number of 07-224-AA. For special applications that require minimum pressure drop and demanding acoustic specifications, contact Universal.

1 Dynamic Insertion Loss in dB for Face Velocities <1500 ft/min

Silencer Length (ft)	Octave Bands (Hz)								
	31.5	63	125	250	500	1K	2K	4K	8K
2	0	2	5	7	13	26	40	39	32
3	0	2	6	9	17	32	50	48	37
4	1	3	7	11	20	40	55	53	41
5	1	4	8	13	23	42	60	56	43

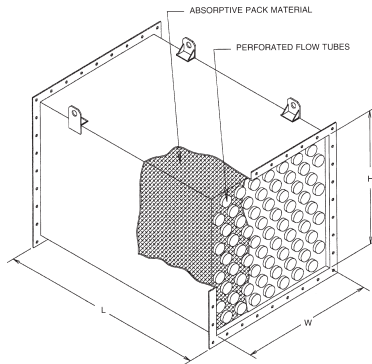

Acousti-Tube dimensions.

The Acousti-Tube silencer comes in standard cross-sectional dimensions and standard flange patterns. Flange patterns also can be designed to match your specifications.

2 Acousti-Tube Part Numbers and Face Areas

Part Number (AV-H x W-L)	Face Area (ft ²)
AT-2 x 2-L	4
AT-2 x 3-L	6
AT-2 x 4-L	8
AT-3 x 4-L	12
AT-4 x 4-L	16
AT-4 x 6-L	24
AT-5 x 6-L	30
AT-6 x 6-L	36
AT-6 x 8-L	48
AT-7.5 x 7.5-L	56
AT-8 x 8-L	64

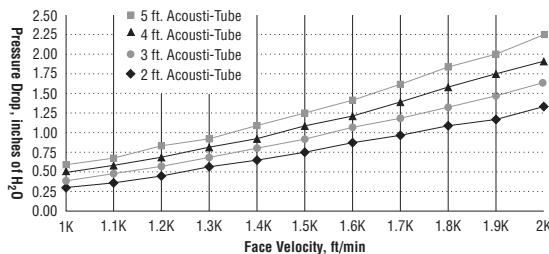

Figure 1
Pressure Drop versus Silencer Face Velocity. To find the pressure drop for gas temperatures other than 60°F, multiply the selected value by 520/ (actual gas temperature °F + 460).





© 2011 Universal Acoustic & Emission Technologies, Inc. All rights reserved.

Toll-Free: 1-888-300-4272
www.universalAET.com
94-1550 Rev 0