



**UNIVERSAL**

*Acoustic & Emission Technologies*

---

# Filters and Filter Silencers

## Technical Literature

---

### Filters

∴ FH Series	Page 2
∴ FRH Series	Page 3
∴ BFH Series	Page 4
∴ FASH Series (HEPA Filter)	Page 7
∴ P-8 Series (Prefilter)	Page 8
∴ P-12F (Final Filter)	Page 8
∴ W-2, DD-2, P-11 and P-5 Filters	Page 9
∴ CCF/CF Series	Page 10–12
∴ ILF/ILFS Series (In-line Filters)	Page 13 & 15
∴ ILFV Series (Vacuum Service In-line Air Filters)	Page 14–15

### Filter-Silencers

∴ FSH Series	Page 2
∴ FCRH Series	Page 3
∴ RF Series	Page 5
∴ CCS/CS Series	Page 10–12
∴ CBF/CBFI Series	Page 6

*Universal AET retains the right to update this technical sheet without notice.  
Please contact your Universal representative to verify the timelines of this technical literature sheet.*





# Application Guide

## Filters and Filter-Silencers

These filters and filter-silencers are available with a variety of filter panels, each with its own restriction characteristics. To reflect that fact, the total pressure drop for a specific filter application is the sum of two pressure drop values:

- 1 The first value is the restriction that can be attributed to the filter housing without filter panels. This value is found in the graphs at right.
- 2 The second value is the restriction through the filter panel media. These values are taken from the table below.

The pressure drop values for the filter panels are listed in the table as pressure drop in inches of water gauge at various flow rates in CFM. The housing pressure drop is shown in graphical form as a function of air flow in CFM versus pressure drop in inches of water gauge.

To avoid confusion, pressure drop values in the graphs include pipe entrance pressure drops from the atmospheric end of the inlet pipe. These drops are significant, contributing as much as 75% of the total pressure drop, and should not be attributed to the filter. Adding the filter transfers these pressure losses to the interior of the filter housing. A pressure drop measurement at the pressure tap on the filter outlet reflects the total:

- ✦ Pipe entrance loss
- ✦ Velocity pressure
- ✦ Housing restriction

CFM per filter
500
600
700
800
900
1,000
1,250
1,500

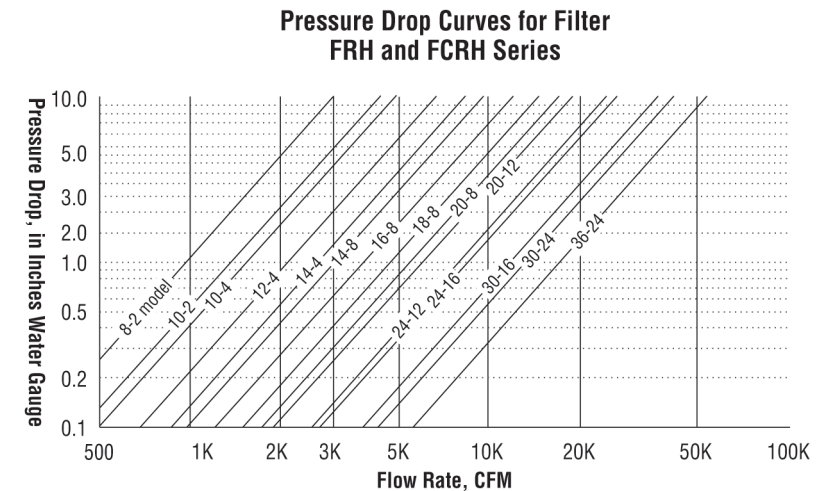
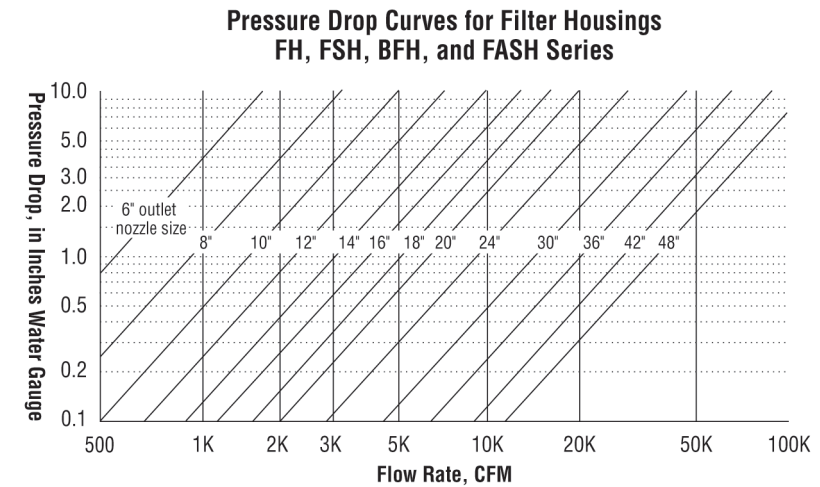

**Pressure Drop Values for 20" x 25" Panel Filters, in Water Gauge**

W-2	DD-2	P-11	W-2 and DD-2	W-2 and P-11	P-8 and P-12F	P-5	W-2 and P-5	DD-2 and P-5
0.01	0.06	0.09	0.07	0.10	0.80	0.28	0.29	0.34
0.02	0.08	0.13	0.10	0.15	0.96	0.35	0.37	0.43
0.03	0.11	0.16	0.14	0.19	1.12	0.42	0.45	0.53
0.03	0.14	0.21	0.17	0.24	1.28	0.49	0.52	0.63
0.04	0.17	0.25	0.21	0.29	1.44	0.56	0.60	0.73
0.05	0.21	0.30	0.26	0.35	1.60	0.64	0.69	0.85
0.08	0.31	0.44	0.39	0.52	2.00	0.83	0.91	1.14
0.12	0.44	0.59	0.56	0.71	2.40	1.04	1.16	1.48



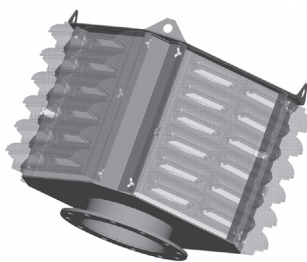

# FH Series Filter

# FSH Series Filter-Silencer

For centrifugal compressors, blowers, engines, and gas turbines. For reciprocating compressors, ask Universal for recommendations.

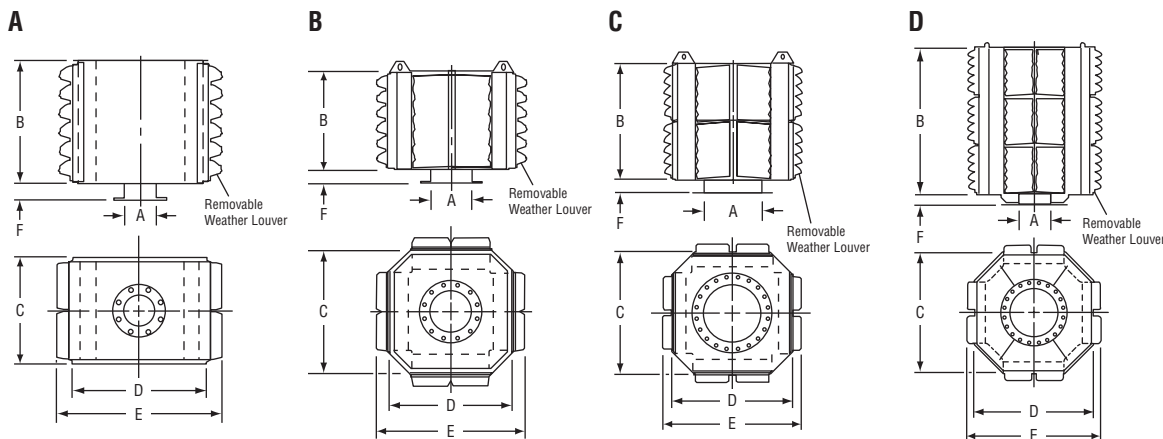

The FH and FSH series use standard panel filters, which are available in a variety of types and efficiencies. The supports for the filter frames inside the housings accommodate conventional 2" deep single-panel filters or, for critical service, two single-panel filters staged in series. In the case of dual-stage systems, use a high-efficiency final filter and a less efficient primary filter. The FSH series has an integrated silencing section for applications that require moderate noise reduction.

All units are fabricated of steel sheet and plate, welded throughout to provide a rugged, long-lasting, trouble-free air filtering component. All models are equipped with a pressure tap and flanges drilled to match 125/150-lb ANSI specifications. Inside and outside housing surfaces are primed and given a finish coat of enamel paint. Suitable mounting legs may be fitted in the field or will be quoted upon application.

All housings come with low-profile, UV-stabilized plastic weather louvers.

### Noise Attenuation

Attenuation, dB	Octave Band Center Frequency, Hz
2	63
3	125
4	250
5	500
8	1,000
13	2,000
14	4,000
13	8,000

### Part Numbers (Standard Units with Louvers)

FH Filter		FSH Filter Silencer		Config.	Cap. CFM	A (nom.)	B	C	D	E	F	Weight		Number and Size of Filter Openings
Model	Part Number	Model	Part Number									FH	FSH	
FH-6-2	36-306-AAL	FSH-6-2	37-306-AAL	A	1,000	6	25.50	23.25	23.25	34.50	5.00	115	145	2, 20×25×4
FH-8-2	36-308-AAL	FSH-8-2	37-308-AAL	A	1,750	8	25.50	23.25	23.25	34.50	5.00	125	150	2, 20×25×4
FH-10-2	36-310-AAL	FSH-10-2	37-310-AAL	A	2,750	10	25.50	23.25	23.25	34.50	5.00	130	160	2, 20×25×4
FH-10-4	36-510-AAL	FSH-10-4	37-510-AAL	B	2,750	10	25.50	32.00	32.00	38.50	5.00	170	200	4, 20×25×4
FH-12-4	36-412-AAL	FSH-12-4	37-412-AAL	B	4,000	12	25.50	32.00	32.00	38.50	5.00	175	210	4, 20×25×4
FH-14-4	36-314-AAL	FSH-14-4	37-314-AAL	B	5,400	14	25.50	32.00	32.00	38.50	5.00	180	220	4, 20×25×4
FH-14-8	36-514-AAL	FSH-14-8	37-514-AAL	C	5,400	14	40.75	42.00	42.00	47.88	5.00	340	405	8, 20×25×4
FH-16-8	36-416-AAL	FSH-16-8	37-416-AAL	C	7,000	16	40.75	42.00	42.00	47.88	5.00	350	420	8, 20×25×4
FH-18-8	36-418-AAL	FSH-18-8	37-418-AAL	C	8,900	18	40.75	42.00	42.00	47.88	5.00	350	430	8, 20×25×4
FH-20-8	36-320-AAL	FSH-20-8	37-320-AAL	C	11,000	20	40.75	42.00	42.00	47.88	5.00	365	440	8, 20×25×4
FH-20-12	36-520-AAL	FSH-20-12	37-520-AAL	D	11,000	20	61.00	50.00	50.00	55.88	5.00	600	725	12, 20×25×4
FH-24-12	36-424-AAL	FSH-24-12	37-424-AAL	D	16,000	24	61.00	50.00	50.00	55.88	5.00	610	765	12, 20×25×4
FH-24-16	36-524-AAL	FSH-24-16	37-524-AAL	C	16,000	24	50.75	56.00	56.00	62.50	5.00	695	855	16, 20×25×4
FH-30-16	36-330-AAL	FSH-30-16	37-330-AAL	C	20,500	30	50.75	56.00	56.00	62.50	5.00	795	960	16, 20×25×4
FH-30-24	36-530-AAL	FSH-30-24	37-530-AAL	D	20,500	30	76.00	56.00	56.00	62.50	5.00	1,035	1,340	24, 20×25×4
FH-36-24	36-336-AAL	FSH-36-24	37-336-AAL	D	35,500	36	76.00	56.00	56.00	62.50	5.00	1,085	1,670	24, 20×25×4
FH-42-36	36-342-AAL	FSH-42-36	37-342-AAL	D	48,000	42	76.00	81.00	81.00	87.00	6.00	2,450	2,900	36, 20×25×4
FH-48-48	36-348-AAL	FSH-48-48	37-348-AAL	D	63,000	48	101.38	81.00	81.00	87.00	6.00	2,870	3,565	48, 20×25×4

Nominal capacity is based on an exit velocity of approximately 5,000 ft/min. Filter element capacity may be greater, but this is unrelated to unit capacity. 4"-deep filter frames will hold single or dual elements. Weights include the weights of weather louvers only. Refer to page 8 for filter element details.

# FRH Series Filter

# FCRH Series Filter-Silencer

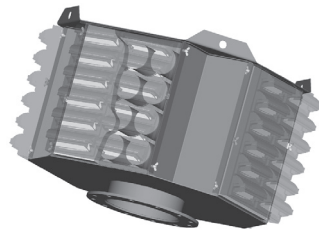

For centrifugal compressors, blowers, engines, and gas turbines. For reciprocating compressors, ask Universal for recommendations.

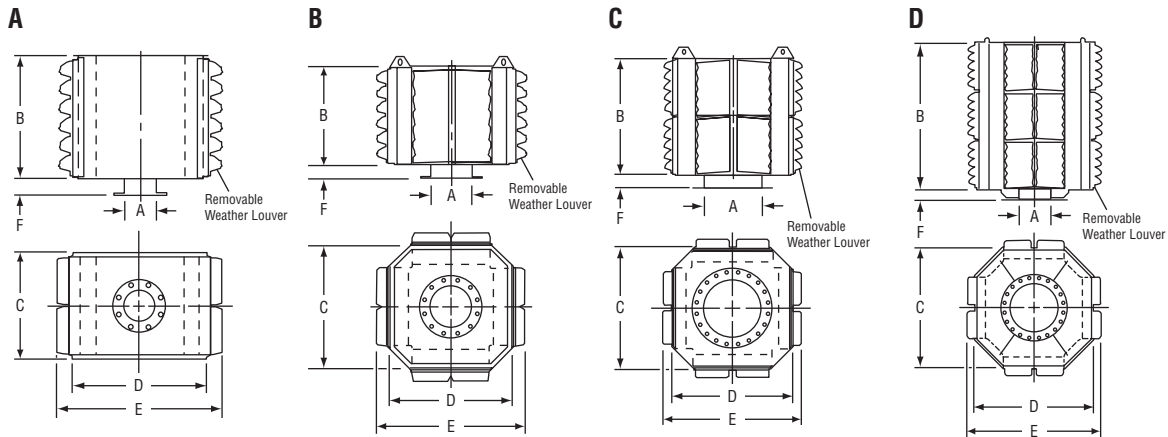

These products are similar to the FH and FSH series, except that the FRH and FCRH series are two-stage filters. The second stage consists of a battery of 12 cartridge filters for each 20" x 25" x 2" prefilter.

The high-efficiency P-5 cartridge filters have threaded ends that screw into individual receptacles. As each P-5 filter is removed and replaced, less than 4 in<sup>2</sup> is exposed to the flow of unfiltered air, so "hot swap" changeouts (while the system is in operation) are an option for these units.

Usually, a moderately efficient filter panel is

used as the first-stage element. The FCRH series has an integrated silencing section that provides moderate noise reduction.

All units are fabricated of steel sheet and plate, welded throughout to provide a rugged, long-lasting, trouble-free air filtering component. All models are equipped with a pressure tap and flange drilled to match 125/150-lb ANSI specifications. Inside and outside surfaces are primed and given a finish coat of enamel paint. All housings come with low-profile, UV-stabilized high-density polyethylene weather louvers.

### Noise Attenuation for FCRH

Attenuation, dB	Octave Band Center Frequency, Hz
2	63
3	125
4	250
5	500
8	1,000
13	2,000
14	4,000
13	8,000

### Part Numbers (Standard Units with Louvers)

FRH Filter		FCRH Filter Silencer		Config.	Cap. CFM	A (nom.)	B	C	D	E	F	Weight		Number and Size of Filter Openings	Final Filters
Model	Part Number	Model	Part Number									FRH	FCRH		
FRH-8-2	38-308-AAL	FCRH-8-2	39-308-AAL	A	1,750	8	25.50	22.25	40.00	46.50	3.50	205	245	2, 20x25x2	24
FRH-10-2	38-310-AAL	FCRH-10-2	39-310-AAL	A	2,750	10	25.50	22.25	40.00	46.50	3.50	210	255	2, 20x25x2	24
FRH-10-4	38-510-AAL	FCRH-10-4	39-510-AAL	B	2,750	10	25.50	42.00	42.00	48.50	3.50	375	385	4, 20x25x2	48
FRH-12-4	38-412-AAL	FCRH-12-4	39-412-AAL	B	4,000	12	25.50	42.00	42.00	48.50	3.50	380	435	4, 20x25x2	48
FRH-14-4	38-314-AAL	FCRH-14-4	39-314-AAL	B	5,400	14	25.50	42.00	42.00	48.50	3.50	395	440	4, 20x25x2	48
FRH-14-8	38-514-AAL	FCRH-14-8	39-514-AAL	C	5,400	14	40.75	52.00	52.00	48.50	3.50	655	735	8, 20x25x2	96
FRH-16-8	38-416-AAL	FCRH-16-8	39-416-AAL	C	7,000	16	40.75	52.00	52.00	57.88	4.50	665	745	8, 20x25x2	96
FRH-18-8	38-418-AAL	FCRH-18-8	39-418-AAL	C	8,900	18	40.75	52.00	52.00	57.88	4.50	665	755	8, 20x25x2	96
FRH-20-8	38-320-AAL	FCRH-20-8	39-320-AAL	C	11,000	20	40.75	52.00	52.00	57.88	4.50	675	765	8, 20x25x2	96
FRH-20-12	38-520-AAL	FCRH-20-12	39-520-AAL	D	11,000	20	61.00	60.00	60.00	65.88	4.50	1,265	1,515	12, 20x25x2	144
FRH-24-12	38-424-AAL	FCRH-24-12	39-424-AAL	D	16,000	24	61.00	60.00	60.00	65.88	4.50	1,315	1,565	12, 20x25x2	144
FRH-24-16	38-524-AAL	FCRH-24-16	39-524-AAL	C	16,000	24	50.75	66.00	66.00	72.50	4.50	1,440	1,640	16, 20x25x2	192
FRH-30-16	38-330-AAL	FCRH-30-16	39-330-AAL	C	20,500	30	50.75	66.00	66.00	72.50	4.50	1,490	1,690	16, 20x25x2	192
FRH-30-24	38-530-AAL	FCRH-30-24	39-530-AAL	D	20,500	30	76.00	72.00	72.00	78.50	4.50	2,130	2,480	24, 20x25x2	288
FRH-36-24	38-336-AAL	FCRH-36-24	39-336AAL	D	35,500	36	76.00	72.00	72.00	78.50	4.50	2,230	2,630	24, 20x25x2	288

Nominal capacity is based on an exit velocity of approximately 5,000 ft/min. Filter element capacity may be greater, but this is unrelated to unit capacity. 2"-deep filter frames will hold single or dual elements. Refer to page 8 for filter element details.

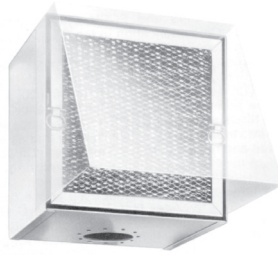

For centrifugal compressors, blowers, engines, and gas turbines. For reciprocating compressors, ask Universal for recommendations.

## BFH Series Filter

**A**

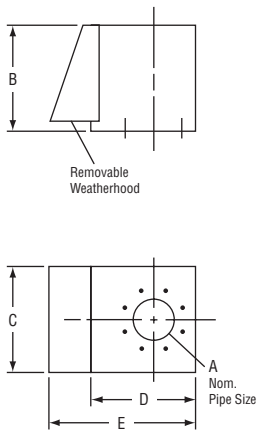

**B**

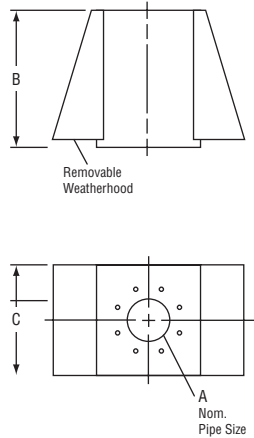

**C**

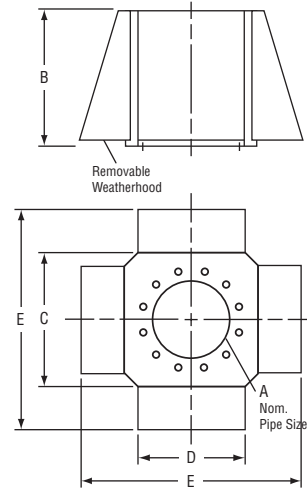

The Universal BFH Series air filter is a compact, inexpensive unit designed for standard panel filters, which are available in a variety of types and efficiencies. Where noise is a consideration, the BFH is used in series with a separate inlet silencer. The filter frames accommodate conventional 2"-deep single-panel filter elements, single stage only.

These units are fabricated of steel sheet and plate, welded throughout, to provide a rugged, long-lasting, trouble-free air filtering component. The filter is equipped with removable weather louvers. For convenience of mounting, the bottom plate contains an opening and bolting pattern that matches 125/150 lb ANSI flange specifications. Inside and outside housing surfaces are primed and given a finish coat of enamel paint.

### Part Numbers (Standard Units with Louvers)

Filter	Part Number	Config.	Capacity CFM	A	B	C	D	E	Weight	Number and Size of Filter Openings
BFH-4-1	35-304-AAL	A	450	4	20.5	26.25	15	18	45	1, 20×25×4
BFH-5-1	35-305-AAL	A	700	5	20.5	26.25	16	19	50	1, 20×25×4
BFH-6-1	35-306-AAL	A	1,000	6	20.5	26.25	17	20	55	1, 20×25×4
BFH-8-2	35-308-AAL	B	1,750	8	25.5	21.25	20	26.5	70	2, 20×25×4
BFH-10-2	35-310-AAL	B	2,750	10	25.5	21.25	23	29.5	70	2, 20×25×4
BFH-10-4	35-410-AAL	C	2,750	10	25.5	27.25	27.25	33.5	85	4, 20×25×4
BFH-12-4	35-412-AAL	C	4,000	12	25.5	27.25	27.25	33.5	85	4, 20×25×4
BFH-14-4	35-314-AAL	C	5,000	14	25.5	27.25	27.25	33.5	85	4, 20×25×4

Nominal capacity is based on exit velocity of approximately 5,000 ft/min. Filter element capacity may be greater, but this is unrelated to unit capacity. Weights do not include the weight of the filter elements. 2"-deep filter frames will hold a single filter element. **Refer to page 8 for filter element details.**



- For intermediate and large positive displacement blowers, reciprocating engines, and compressors.

# RF Series

## Filter-Silencer

The RF Series Filter-Silencer is a high-degree reactive (chamber) silencer of very rugged construction, which is typically required for large, slow-speed reciprocating or positive displacement machinery, where broadband noise attenuation and inherent vibration-resistant structural strength is required. Wire mesh panel filters are standard in one of the four configurations shown below.

RF units are fabricated of steel sheet and plate, welded throughout. Filter panels are serviced and replaced through hinged access doors. Flanged connections are drilled to match 125/150# ANSU specifications. Inside and outside surfaces are given a shop coat of rust inhibitive primer. The exterior may be finish-painted in the field if desirable.

### RF Series

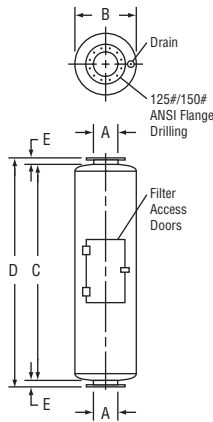

### RFY Series

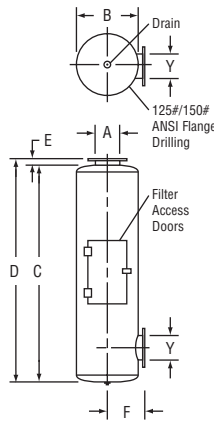

### RFS Series

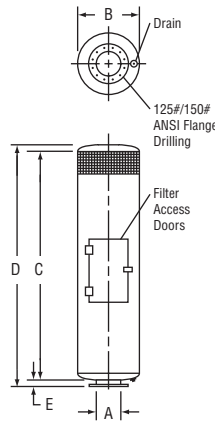

### RFSY Series

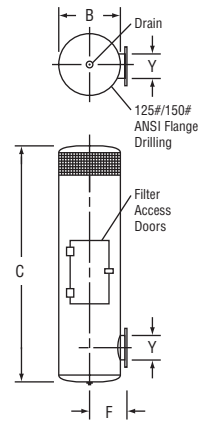

### Noise Attenuation

Attenuation, dB	Octave Band Center Frequency, Hz
28	63
29	125
29	250
28	500
26	1,000
25	2,000
24	4,000
23	8,000

### Part Numbers (Standard with Wire Mesh Elements)

RF Series		RFY Series		RFS Series	
Model	Part Number	Model	Part Number	Model	Part Number
RF-6	42-106-AA	RFY-6	42-206-AA	RFS-6	43-106-AA
RF-8	42-108-AA	RFY-8	42-208-AA	RFS-8	43-108-AA
RF-10	42-110-AA	RFY-10	42-210-AA	RFS-10	43-110-AA
RF-12	42-112-AA	RFY-12	42-212-AA	RFS-12	43-112-AA
RF-14	42-114-AA	RFY-14	42-214-AA	RFS-14	43-114-AA
RF-16	42-116-AA	RFY-16	42-216-AA	RFS-16	43-116-AA
RF-18	42-118-AA	RFY-18	42-218-AA	RFS-18	43-118-AA
RF-20	42-120-AA	RFY-20	42-220-AA	RFS-20	43-120-AA
RF-22	42-122-AA	RFY-22	42-222-AA	RFS-22	43-122-AA
RF-24	42-124-AA	RFY-24	42-224-AA	RFS-24	43-124-AA
RF-26	42-126-AA	RFY-26	42-226-AA	RFS-26	43-126-AA
RF-28	42-128-AA	RFY-28	42-228-AA	RFS-28	43-128-AA
RF-30	42-130-AA	RFY-30	42-230-AA	RFS-30	43-130-AA

Refer to page 8 for filter element details.

Model	Nom. Cap. CFM	A	B	C				D			F	Y		Number and Size of Filter Openings	Weight		
				RF	RFY	RFS	RFSY	RF	RFY	RFS		Min.	Min.		RF	RFY	RFS
RF/RFY/RFS-6	1,050	6	24	79.25	79.5	91.75	13	86.25	83	95.25	15.5	9	23	1, 20×25×2	400	450	
RF/RFY/RFS-8	1,875	8	24	79.25	79.5	91.75	13	86.25	83	95.25	15.5	9	23	2, 20×25×2	510	530	
RF/RFY/RFS-10	2,950	10	30	105	105.5	91.5	13	112	109	121	18.5	11	34.5	2, 20×25×2	850	920	
RF/RFY/RFS-12	4,250	12	36	125	125.5	137.5	7	132	129	141	21.5	13	40	4, 20×25×2	1,220	1,260	
RF/RFY/RFS-14	5,600	14	36	124.25	125.5	143.5	21	131.5	129	147	21.5	14	39	4, 20×25×2	1,280	1,340	
RF/RFY/RFS-16	7,500	16	42	143	144.5	163	21	150	148	166.5	24.5	16	45	6, 20×25×2	1,950	2,070	
RF/RFY/RFS-18	9,500	18	42	167.5	168.5	192.5	26.25	174.25	172	196	28.5	17	56	8, 20×25×2	2,170	2,290	
RF/RFY/RFS-20	11,500	20	48	181	182.5	206.5	27.25	190	187	211	28.5	19	56	8, 20×25×2	2,900	3,000	
RF/RFY/RFS-22	14,000	22	48	198.5	200	230.5	27.25	207.5	204.5	235	31.5	20	60	12, 20×25×2	3,090	3,360	
RF/RFY/RFS-24	16,500	24	54	218.5	220	250.5	—	227.5	224.5	255	31.5	22	66	12, 20×25×2	3,900	4,190	
RF/RFY/RFS-26	20,000	26	54	231	232.5	268.5	—	240	237	273	34.5	24	72	12, 20×25×2	4,160	4,470	
RF/RFY/RFS-28	23,000	28	60	250	151.5	288	—	259	256	292.5	37.5	26	78	18, 20×25×2	5,360	5,760	
RF/RFY/RFS-30	26,000	30	66	269.5	271.5	307.5	27.25	278.5	276	312	115	27	77	18, 20×25×2	5,460	6,970	

Nominal capacity is based on exit velocity of approximately 5,400 ft/min. Filter element capacity may be greater, but this is unrelated to unit capacity.

# CBF/CBFI Series

## Compact Blower Inlet Filter-Silencer

### Filter and silencer combined in one unit.

The CBF and CBFI have the acoustic capabilities of the Universal Silencer RIS Series silencers and the filtration performance of CC series filters.

**Reduced cost**, overall package size, weight, storage space, freight cost and damage.

Approximately one third the size of conventional blower silencer, with the added benefit of excellent, high-efficiency filtration.

**Reduced overall package noise** without further acoustic treatment.

**Versatile**—Suitable for inlet applications in confined areas, outdoor or indoor, without compromising acoustic or pressure drop performance.

**CBF Series (outdoor use)**

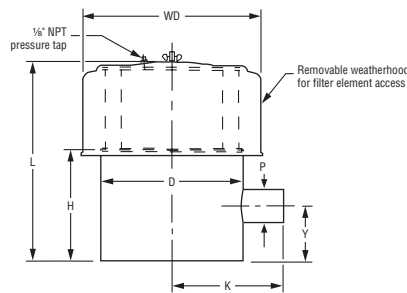

**CBFI Series (indoor use)**

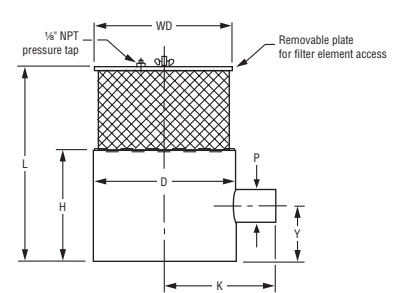

P (nom.)	Element Part Number		
	Paper	Felt	Wire
2	81-0471*	81-1203*	81-1036*
2.5	81-0471*	81-1203*	81-1036*
3	81-1063	81-1205	81-1038
4	81-1063	81-1205	81-1038
5	81-0475	81-1207	81-1040
6	81-0475	81-1207	81-1040
8	81-1163	81-1209	81-1200
10	81-1163	81-1209	81-1200
12	81-1164	81-1210	81-1201

\*Pair of elements required (stacked).

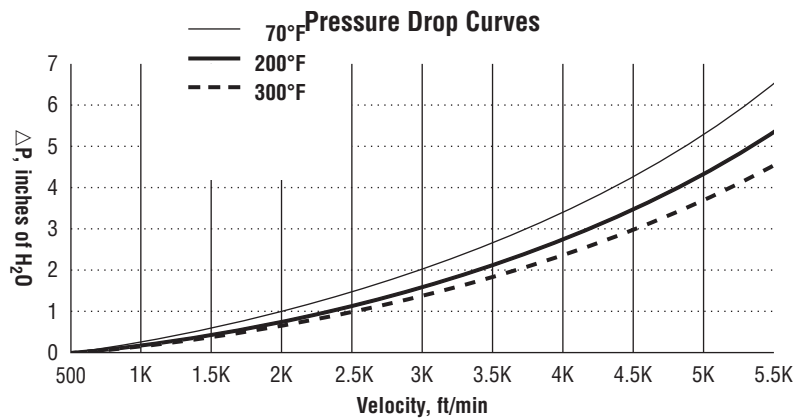

### Models, Dimensions, Weights and Elements

P (nom.)	CBF/CBFI					CFM CAP	CBF			CBFI			
	D	H	Y	K	Part		WD	L	Weight	Part	WD	L <sub>1</sub>	Weight
2	8	8	4	7	34-702-AA	120	10	13.25	25	34-G02-AA	6.5	13	20
2.5	8	9.5	4.75	7	34-725-AA	175	10	14.75	25	34-G25-AA	6.5	14.5	25
3	12	10.5	5.25	9	34-703-AA	275	16	17	50	34-G03-AA	10.5	16.5	40
4	12	15	7.5	9	34-704-AA	500	16	21.25	60	34-G04-AA	10.5	20.875	55
5	16	17	8.5	11	34-705-AA	750	20	26	85	34-G05-AA	14	25.625	85
6	16	23	11.5	11	34-706-AA	1,100	20	32	105	34-G06-AA	14	31.625	100
8	24	27.5	13.75	15.5	34-708-AA	2,200	30	39	215	34-G08-AA	17	37.5	195
10	30	35.5	17.75	18.5	34-710-AA	3,000	36	46.44	335	34-G10-AA	17	45.375	305
12	34	39.5	19.75	20.5	34-712-AA	4,300	40	54.5	430	34-G12-AA	24	53.75	370

Notes: 1. Non-ASME Code construction suitable for 15" Hg vacuum.  
2. Weights are approximate and do not include the weight of the filter element.



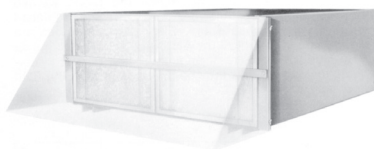

# FASH Series

## HEPA Filter

- For centrifugal compressors, blowers, and gas turbines.

The FASH Series HEPA Filter-Silencer represents the ultimate high-efficiency air filtration for industrial applications. The unit uses first- and second-stage elements, having a combined depth of 20", to provide exceptional efficiency on ultra-fine particulates and a large surface area for low flow resistance and high dirt-retention capacity. Filtration efficiency is 99.97% on particles 0.3 microns.

Instead of a conventional gasket seal, the FASH utilizes a unique fluid seal for the final filter. A channel on the downstream side of the P-12F final filter holds a stable silicon gel fluid. The frame has a projecting tongue which is immersed in the fluid. The result is a 100% bypass-free system.

For economy, the filters are staged, so that the less expensive pre-filter "roughing" pad and primary filter can be changed more frequently than the final filter. Under typical conditions, the pre-filter will require replacement about once a year, while the final filter may provide two to three years of service. Specification details for the P-8 pre-filter and P-12F final filter can be found on page 7.

The FASH features an integral silencing section for a moderate degree of noise attenuation. The unit is constructed of heavy-duty steel sheet and plate, welded throughout, making it a rugged, long-lasting, trouble-free air filtering component.

All models are equipped with removable weatherhoods, pressure tap, and flanges drilled to match 125/150 lb ANSI specifications. Inside and outside surfaces are primed and given a finish coat of enamel paint.

Suitable mounting legs may be fitted in the field, or quoted upon application.

### Noise Attenuation

Attenuation, dB	Octave Band Center Frequency, Hz
2	63
3	125
4	250
5	500
8	1,000
13	2,000
14	4,000
13	8,000

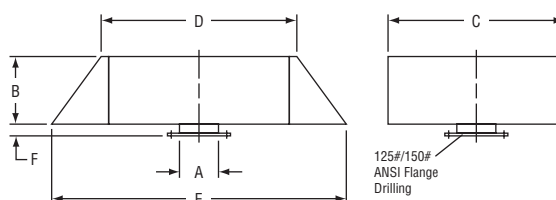

Model	Part Number	Nom. Cap. CFM	A	B	C	D	E	F	Weight	Number of Elements
FASH-10-4	40-510-AA	2,750	10	25.5	32	32	55	3.5	225	2
FASH-12-4	40-412-AA	4,000	12	25.5	32	32	55	3.5	240	2
FASH-14-4	40-314-AA	5,400	14	25.5	32	32	55	3.5	245	4
FASH-14-8	40-514-AA	5,400	14	40.75	42	42	61	4.5	465	4
FASH-16-8	40-416-AA	7,000	16	40.75	42	42	61	4.5	475	4
FASH-18-8	40-418-AA	8,900	18	40.75	42	42	61	4.5	485	8
FASH-20-8	40-320-AA	11,000	20	40.75	42	42	61	4.5	495	8
FASH-20-12	40-520-AA	11,000	20	61	50	50	69	4.5	810	8
FASH-24-12	40-424-AA	16,000	24	61	50	50	69	4.5	850	8
FASH-24-16	40-524-AA	16,000	24	50.75	52	52	75	4.5	850	12
FASH-30-16	40-330-AA	20,500	30	50.75	52	52	75	4.5	955	12
FASH-30-24	40-530-AA	20,500	30	76	62	62	85	4.5	1,535	16
FASH-36-24	40-336-AA	35,500	36	76	62	62	85	4.5	1,865	16
FASH-42-36	40-342-AA	48,000	42	76	72	72	95	6	2,320	24
FASH-48-48	40-348-AA	63,000	48	101.25	78	78	101	6	3,750	24

Nominal capacity is based on exit velocity of approximately 5,000 ft/min. Filter element capacity may be greater, but this is unrelated to unit capacity. 4" deep filter frames will hold single elements or dual elements. Weights do not include the weight of the filter elements. Weight is measured with steel weatherhoods. Louvered weatherhoods reduce weight by 7 lb per filter opening.



# P-8 Series

Prefilter

# P-12F Series

Final Filter

- For centrifugal compressors, blowers, engines, and gas turbines. For reciprocating compressors, contact Universal Silencer for recommendations.

P-8 and P-12F absolute filter elements are **not** cleanable; they must be replaced with new elements according to these instructions.

### For New Units—Measuring Pressure Drop

When new filters or filter-silencers are installed, make the following two pressure drop measurements and record the results for future reference:

- 1 Measure the pressure drop with all filters installed.
- 2 Measure the pressure drop with the P-8 pre-filters removed, but the P-12F final filters installed; this gives the pressure drop across the final filters.
- 3 Subtract the second value from the first to find the pressure drop across the pre-filters.

### Polyester Pad Replacement

Replace the polyester pad when visibly dirty.

### Filter Replacement

After the units have been in service and the filters are loaded, determine whether the filters need to be replaced as follows:

- 1 Measure the pressure drop with all filters installed and subtract the value measured at installation, when the filters were clean, to find the pressure drop across both loaded filters.
- 2 Measure the pressure drop with the P-8 pre-filters removed, but with the P-12F final filters installed; subtract the value measured at installation, when the final filters were clean; if the difference is more than 2", replace the final filters.
- 3 Subtract the second value from the first to find the pressure drop across the pre-filters. If the difference is more than 2", replace the final filters.

P-8 Prefilter

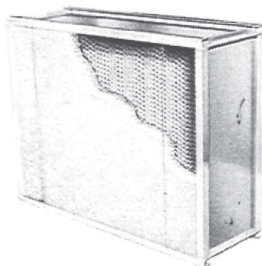

P-12F Final Filter

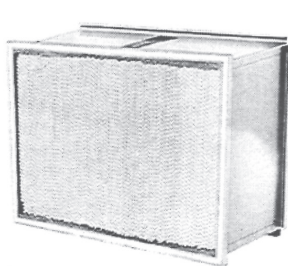

	P-8	P-12F
Seal	Sponge Neoprene Gasket	Silicon Fluid Seal
Filter Media	Waterproof Glass	Waterproof Glass
Separators	Aluminum	Aluminum
Frame	16-Gauge Galvanized Steel	16-Gauge Galvanized Steel
Construction	Pleated Media over Corrugated Separators	Pleated Media over Corrugated Separators
Tools Needed for Removal	Part Number 80-0457 Removal Tool (Need 2)	Part Number 80-0457 Removal Tool (Need 2)

Model	Part Number	Weight	Size	Pressure Drop, Clean Filter	Pressure Drop, Clean Filter
P-8 Prefilter	81-0398 81-0400*	27	19.5×24.5×8	Individually tested and certified 85% efficient by N.B.S. test	0.6" water at 1,250 CFM
P-12F Final Filter	81-0429	47	19.5×24.5×11.5	Individually tested and certified 99.97% efficient by D.O.P. test for particle size 0.3 micron	0.6" water at 1,250 CFM

\* The polyester pad (part number 81-0400) is a 2" thick "roughing" filter that fits on the face of the P-8 prefilter. It may be purchased separately in cartons of 12 and should be replaced when it is visibly dirty. Follow the service instructions for replacement.

Universal offers a wide range of sizes and types of air filters and filter-silencers for application on air-moving equipment and internal combustion engines. This catalog covers our standard off-the shelf models. Most models are stocked for immediate shipment. Special types and configurations, as well as larger sizes that are not cataloged, are quoted upon application to meet specific requirements.

### Easy to specify and order

When you work with Universal, you can simply provide the flow conditions and equipment manufacturer's information, and we can recommend a filter or filter-silencer best suited for your application. Using your information, we can prepare a comprehensive technical proposal and price quotation.

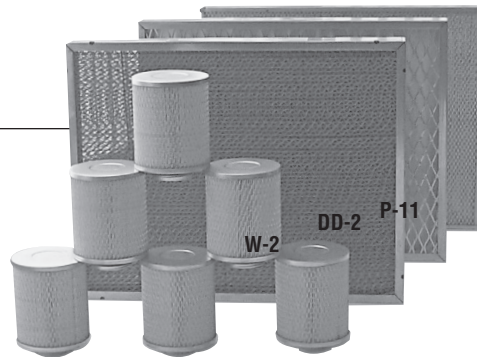

## Filter Elements

### Filter and Filter-Silencers

	W-2	DD-2	P-11	P-5	P-5EC
Frame Material	Galvanized Steel	Galvanized Steel	Aluminized Steel	Steel	Epoxy-Coated Steel
Media	Crimped Galvanized Steel Wire Mesh	Felted Synthetic (Polyester)	Paper	Paper	Paper
Dry or Treated	Oil-Free Adhesive	Dry	Dry	Dry	Dry
Cleaning	Soap or Solvent Wash	Compressed Air or Soap Wash	Compressed Air	Compressed Air	Compressed Air

Resistance Filter Type	Available Sizes	Part Number	Weight	Rated Flow (CFM)	Media Surface Area (ft²)	Efficiency	Initial Resistance at Rated Flow (in. of H <sub>2</sub> O)
W-2-50	12×12×2	81-0410	5	360	1.0	93% on 10 microns	0.08
W-2-10	16×20×2	81-0162	9	800	2.2		
W-2-20	16×25×2	81-0163	10	1,000	2.8		
W-2-30	20×20×2	81-0164	10	1,000	2.8		
W-2-40	20×25×2	81-0165	12.5	1,250	3.5		
DD-2-50	12×12×2	81-0411	4	360	1.7	99% on 10 microns	0.31
DD-2-10	16×20×2	81-0170	7	800	3.7		
DD-2-20	16×25×2	81-0171	8.5	1,000	4.6		
DD-2-30	20×20×2	81-0172	8.5	1,000	4.6		
DD-2-40	20×25×2	81-0173	10	1,250	5.7		
P-11	20×25×2	81-0326	8	1,250	94.0	99.5% on 2 microns	0.44
P-5	5 dia. × 6.68 long	81-0317*	.75	105	6.7	99.5% on 2 microns	0.83
P-5EC5	5 dia. × 6.68 long	81-0421*	.75	105	6.7	75% on 2 microns 99.5% overall 99% on 10 microns 75% on 2 microns	0.83

\*48 filters per case.

For dry filters, cleaning instructions are included with each unit. Filter types DD-2 and W-2 are available with stainless steel or aluminum frames. Type W-2 is available with stainless steel or aluminum media.



# CCS/CS Series

Filter-Silencers

# CCF/CF Series

Filters

**CCS Series** (with weatherhood)

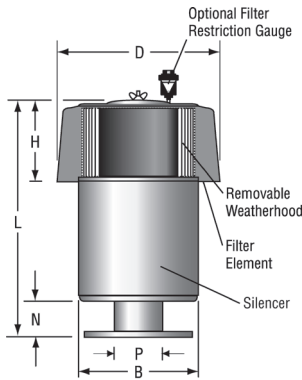

**CS Series** (with top plate)

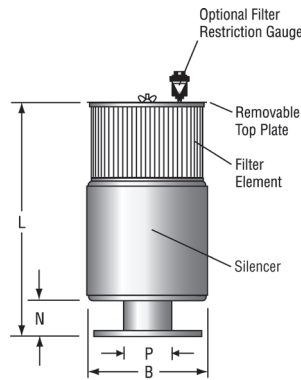

**CCF Series** (with weatherhood)

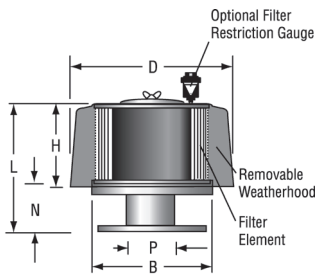

**CF Series** (with top plate)

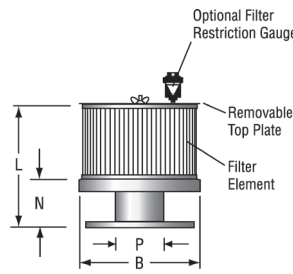

Universal's cartridge filters and filter-silencers offer high-performance filtration and silencing in a convenient, economical cartridge configuration. Choose from four standard models for pipe sizes ranging from .5" to 16" and for flow capacities ranging from 15 to 7,700 CFM. Three types of filter element media—pleated paper, pleated felt, or wire mesh—are available to suit your application.

The CCF and CF series filters are high-quality air filters without a silencing section. The CCF has a removable weatherhood, and the CF has a removable top plate. Our CCS and CS intake filter-silencers have a built-in silencing section. The CCS features a removable weatherhood, and the CS has a removable top plate for easy access to the filter element.

## Performance Benefits

### • Durability

Weatherhoods for CCF and CCS sizes 2.5" through 5" are rugged blue ABS composite material that may be painted. All other components are carbon steel construction with a high-quality semi-gloss enamel finish.

### • High Performance

Unique design options, combined with the latest manufacturing techniques, ensure optimum performance and long life even under demanding conditions.

### • Functional

Choice of filter only or filter-silencer.

### • Easy to Maintain

Removable lightweight weatherhood (CCS and CCF) or removable top plate (CS and CF) for easy access to the filter element.

### • Versatile

Interchangeable element options for desired filtration characteristics in the same housing.

## Part Numbers

Pipe Size	CCS	CS	CCF	CF
.5	34-K50-TT*	34-M50-TT*		
.75	34-K70-TT*	34-M70-TT*	<i>Sizes .5"-1" Use CCS or CS Series</i>	
1	34-K01-TT*	34-M01-TT*		
1.25	34-K21-TT*	34-M21-TT*	34-L21-TT*	34-N21-TT*
1.5	34-K15-TT*	34-M15-TT*	34-L15-TT*	34-N15-TT*
2	34-K02-TT*	34-M02-TT*	34-L02-TT*	34-N02-TT*
2.5	34-K25-TT*	34-M25-TT*	34-L25-TT*	34-N25-TT*
3	34-K03-TT*	34-M03-TT*	34-L03-TT*	34-N03-TT*
3.5	34-K35-TT*	34-M35-TT*	34-L35-TT*	34-N35-TT*
4	34-K04-TT*	34-M04-TT*	34-L04-TT*	34-N04-TT*
4	34-K04-AA*	34-M04-AA*	34-L04-AA*	34-N04-AA*
5	34-K05-TT*	34-M05-TT*	34-L05-TT*	34-N05-TT*
5	34-K05-AA*	34-M05-AA*	34-L05-AA*	34-N05-AA*
6	34-K06-AA*	34-M06-AA*	34-L06-AA*	34-N06-AA*
8	34-K08-AA*	34-M08-AA*	34-L08-AA*	34-N08-AA*
10	34-K10-AA*	34-M10-AA*	34-L10-AA*	34-N10-AA*
12	34-K12-AA*	34-M12-AA*	34-L12-AA*	34-N12-AA*
14	34-K14-AA*	34-M14-AA*	34-L14-AA*	34-N14-AA*
16	34-K16-AA*	34-M16-AA*	34-L16-AA*	34-N16-AA*

\*Specify "P" at end of part number for unit with pleated paper elements, "F" for pleated felt or "W" for wire mesh. Refer to page 11 for filter element details.

# CCS/CS Series

## Filter-Silencers

# CCF/CF Series

## Filters

### Noise Attenuation, CCS/CS

Attenuation, dB	Octave Band Center Frequency, Hz
5	63
8	125
10	250
12	500
14	1,000
14	2,000
14	4,000
14	8,000

### Pressure Drop, All Models

Pressure Drop (in. of H <sub>2</sub> O)	Percentage of Rated Flow
0.7	50%
1.6	75%
2.8	100%
4.4	125%
6.3	150%

P (size)	Rated Flow Cap. (CFM)	D	H	B	N				L				Approx. Weight with Paper Elements			
					CCF	CCS	CF	CS	CCF	CCS	CF	CS	CCF	CCS	CF	CS
.5	15	8.00	3.13	6.00	Use	—	Use	—	Use	6.50	Use	6.50	Use	7	Use	7
.75	22	8.00	3.13	6.00	CCS	—	CS	—	CCS	6.50	CS	6.50	CCS	7	CS	7
1	35	8.00	3.13	6.00	Series	—	Series	—	Series	6.50	Series	6.50	Series	7	Series	7
1.25	60	9.00	3.50	6.50	—	—	—	—	3.50	7.88	3.50	7.88	9	10	5	9
1.5	75	9.00	3.50	6.50	—	—	—	—	3.50	7.88	3.50	7.88	9	10	5	9
2	120	9.00	3.50	6.50	—	—	—	—	3.50	7.88	3.50	7.88	8	10	5	8
2.5	190	13.44	6.75	10.00	1.00	1.00	1.00	1.00	7.50	17.69	7.13	17.31	11	19	10	18
3	275	13.44	6.75	10.00	1.00	1.00	1.00	1.00	7.50	17.69	7.13	17.31	10	18	9	17
3.5	375	13.44	6.75	10.00	1.13	1.13	1.13	1.13	7.63	17.69	7.25	17.31	13	20	12	19
4 (NPT)	500	13.44	6.75	10.00	1.13	1.13	1.13	1.13	7.63	17.69	7.25	17.31	12	19	11	18
4 (flanged)	500	13.44	6.75	10.00	4.00	3.00	4.00	3.00	10.50	19.63	10.13	19.25	14	21	13	20
5 (NPT)	750	13.44	6.75	10.00	1.81	1.81	1.81	1.81	8.38	18.25	8.00	17.88	12	19	11	18
5 (flanged)	750	13.44	6.75	10.00	4.00	3.00	4.00	3.00	10.50	19.56	10.13	19.13	16	23	15	22
6	1,100	18.00	9.50	14.00	4.00	3.00	4.00	3.00	13.31	25.25	12.75	24.75	31	43	23	35
8	2,200	20.00	18.00	14.00	4.00	3.00	4.00	3.00	21.88	33.88	21.38	33.38	43	56	30	43
10	3,000	24.00	11.50	18.00	4.00	3.00	4.00	3.00	15.38	29.25	14.19	28.13	52	83	41	67
12	4,300	24.00	11.50	18.00	4.00	3.00	4.00	3.00	15.38	29.25	14.19	28.13	64	91	48	75
14	5,900	30.00	15.44	24.00	4.00	3.00	4.00	3.00	19.38	36.25	18.25	35.06	97	143	75	121
16	7,700	30.00	15.44	24.00	4.00	3.00	4.00	3.00	19.38	36.25	18.25	35.06	101	145	79	123

All models have a .125" FNPT tap for installation of a gauge or manometer to monitor pressure drop. Sizes .5" through 3.5" are standard with female pipe thread connection (FNPT). Sizes 4" and 5" are available with female threads or flanges. Please specify "threaded" or "flanged" when you order 4" and 5" sizes. Sizes 6" through 16" are standard with 150# ANSI drilled plate flanges. Rated capacity is based upon exit velocity of approximately 5,500 ft/min. If pressure drop allowance permits, capacity may be increased by as much as 50%.



# CCS/CS/CCF/CF Filter Elements

Three types of filter elements are available for Universal's cartridge filters and filter-silencers. Pleated paper elements provide the highest efficiency and are considered standard. Pleated felt and wire mesh elements are available for less demanding service with respect to efficiency. The three types of elements are completely interchangeable and will fit all CCS, CS, CF or CCF filter housings.

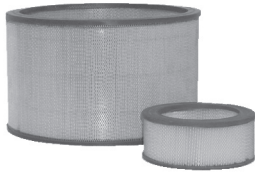

## Pleated Paper Element

### Specifications

- High-quality industrial grade filter paper—pleated and oven-cured during production.
- Oven-cured plastisol end caps with molded sealing beads.
- Media efficiency: 99.5% on 2 microns; 97% on 1 micron.
- Maximum operating temperature: 200°F for units with .5" through 16" pipe sizes.
- Collapse Strength: 25" WC

### Service Instructions

Because of the low cost of the paper element, it is generally treated as a consumable and replaced when dirty. However, depending on customer preference, the paper element may be cleaned with compressed air and reused.

### Compressed Air Cleaning

Carefully direct compressed air (100 PSI maximum) through the dry element, opposite the normal direction of flow. After cleaning, inspect carefully for holes or cracks. If damaged, replace element.



## Pleated Felt Element

### Specifications

- Durable polyester felt media—pleated.
- Oven-cured plastisol end caps with molded sealing beads (larger elements for pipe sizes 10", 12", 14", and 16" have metal end caps with closed cell rubber gaskets).
- Media efficiency: 99% on 10 microns.
- Maximum operating temperature: 200°F for units with .5" through 8" pipe sizes, 250°F for units with 10" through 18" pipe sizes using elements with metal end caps.
- Collapse Strength: 25" WC

### Service Instructions

Pleated felt elements may be cleaned with compressed air (as described for paper elements) or water and reused.

### Water Cleaning

Rap gently to dislodge accumulated dirt, soak thoroughly approximately 15 minutes in warm water and mild detergent. Rinse thoroughly under low pressure water. Air dry—do not dry with compressed air. After cleaning, inspect carefully for holes or cracks. If damaged, replace element.

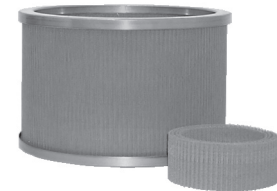

## Wire Mesh Element

### Specifications

- Galvanized wire-mesh media—corrugated construction.
- May be cleaned and reused indefinitely.
- Wire mesh elements are considered "roughing" filters and are not recommended for applications which require efficient filtration of fine particles.
- Approximate efficiency: 93% on 10 microns. Efficiency will vary with element oil or adhesive coverage.
- Maximum operating temperature: 200°F for .5" through 16" with oil-free adhesive (flash point of adhesive is 235°F) and 300°F for .5" through 16" without adhesive.

### Service Instructions

New elements are delivered pre-treated with Universal's oil-free adhesive. See the back page for details. For best efficiency, wire mesh elements must be retreated after each cleaning. Spray the element on both sides with Universal Oil-Free Adhesive, P/N 81-0323, following the directions on the container. For oil treatment, dip the element in SAE 30–50 motor oil and drain thoroughly before using.

### Cleaning

To clean wire mesh elements, wash in solvent or warm water and detergent in a container large enough for complete immersion of element. Rinse completely, drain, and either air dry or use compressed air. After cleaning and drying, retreat the element with oil-free adhesive or oil as described.

P (Nom.)	Replacement Element Part Number		
	Paper	Felt	Wire Mesh
.5	81-0470	81-1202	81-1035
.75	81-0470	81-1202	81-1035
1	81-0470	81-1202	81-1035
1.25	81-0471	81-1203	81-1036
1.5	81-0471	81-1203	81-1036
2	81-0471	81-1203	81-1036
2.5	81-1063, 81-0472 (old)	81-1205, 81-1204 (old)	81-1038, 81-1037 (old)
3	81-1063, 81-0472 (old)	81-1205, 81-1204 (old)	81-1038, 81-1037 (old)
3.5	81-1063	81-1205	81-1038
4	81-1063	81-1205	81-1038
5	81-1063, 81-0474 (old)	81-1205, 81-1206 (old)	81-1038, 81-1039 (old)
6	81-0475	81-1207	81-1040
8	81-0475 (2)	81-1207 (2)	81-1040, (2) 81-1199 (old)
10	81-1163	81-1209	81-1200
12	81-1163	81-1209	81-1200
14	81-1164	81-1210	81-1201
16	81-1164	81-1210	81-1201

Toll-Free: 1-888-300-4272  
www.universalAET.com  
94-1553 Rev 0

Universal's ILF and ILFS Series of in-line air filters are designed to withstand the demanding requirements of pressure and vacuum applications. Choose from ten standard sizes ranging from 3" to 18" and flow capacities ranging from 275 to 9,700 CFM. Three types of filter element media—pleated paper, pleated felt, or wire mesh—are available to suit your application.

# ILF/ILFS Series

## In-line Filters

### ILF Series

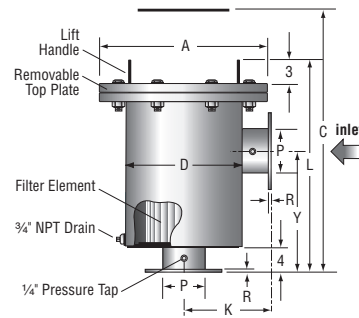

### ILFS Series

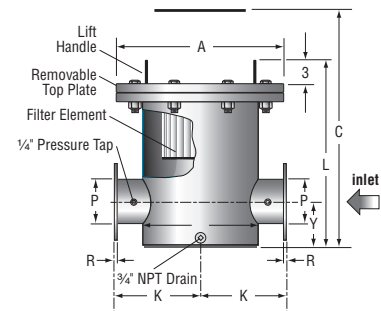

### Durable Construction

- Carbon steel construction with a high-quality blue enamel finish.
- Easily removable top plate for access to the filter element.
- ASME Code construction and special materials, such as stainless steel, are available.

### Customize to Your Application

- Designed for application requirements.
- Optional design features for special production and assembly conditions are available.
- Choose an ILF model for an L-configuration or an ILFS for opposed connections.
- Interchangeable paper, felt, or wire mesh elements, for desired filtration characteristics in a single housing.
- Built-in taps for pressure gauges.

Model	Part Number	P (nom.)	D	L	R	Y	C	A	K	Weight (est.)	Rated Cap. (CFM)	Number of Bolts
ILF-3	34-A03-TT*	3	14	24.25	—	15.5	27	20	11	100	275	8
ILF-4	34-A04-AA*	4	14	24.25	.375	15.5	27	20	11	110	500	8
ILF-5	34-A05-AA*	5	14	25.25	.375	16	28	20	11	120	750	8
ILF-6	34-A06-AA*	6	16	28	.5	18.25	34	22	12	120	1,100	8
ILF-8	34-A08-AA*	8	18	39.5	.5	28.25	45	24	13	140	1,920	8
ILF-10	34-A10-AA*	10	22	35.5	.5	22	42	28	15	295	3,000	12
ILF-12	34-A12-AA*	12	22	37.5	.5	23	44	28	15	315	4,300	12
ILF-14	34-A14-AA*	14	28	41	.5	27	52	34	18	450	5,900	12
ILF-16	34-A16-AA*	16	30	43.75	.5	28	55	36	19	500	7,700	12
ILF-18	34-A18-AA*	18	30	43.75	.5	29	57	36	19	505	9,700	12
ILFS-3	34-B03-TT*	3	14	23	—	5	29	20	11	115	275	8
ILFS-4	34-B04-AA*	4	14	23	.375	5	29	20	11	125	500	8
ILFS-5	34-B05-AA*	5	14	23	.375	5.5	29	20	11	130	750	8
ILFS-6	34-B06-AA*	6	16	27	.5	6	36	22	12	170	1,100	8
ILFS-8	34-B08-AA*	8	20	35	.5	7	44	26	14	245	1,920	8
ILFS-10	34-B10-AA*	10	24	34	.5	8.5	44	30	16	365	3,000	12
ILFS-12	34-B12-AA*	12	24	37	.5	10	47	30	16	395	4,300	12
ILFS-14	34-B14-AA*	14	30	44	.5	11	58	36	19	605	5,900	12
ILFS-16	34-B16-AA*	16	36	48	.5	12.5	62	42	24	895	7,700	12
ILFS-18	34-B18-AA*	18	36	52	.5	13	66	42	24	945	9,700	12

The C dimension is clearance required to remove elements. Non-ASME code construction is suitable for 15" PSI maximum working pressure or 20" Hg operating vacuum. Estimated weight does not include elements. Size 3" is standard with male pipe thread connection (MNPT). Sizes 4" through 18" are standard with 125/150 lb ANSI drilled plate flanges. Rated capacity is based upon flow velocity of approximately 5,500 ft/min. If pressure drop allowance permits, capacity may be increased by as much as 50%. Refer to page 8.14 for filter element details.

\*Specify "P" at end of part number for unit with pleated paper elements, "F" for pleated felt or "W" for wire mesh.

# ILFV Series

## Vacuum Service In-line Air Filters

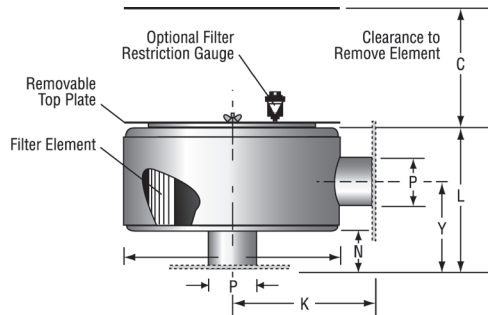

### Filter Elements

Pleated paper elements offer the highest efficiency and are considered “standard” for the ILFV series units. Pleated felt elements are also available for less demanding service. Both element types are completely interchangeable and will fit in any ILFV housing.

Universal’s new ILFV Series of in-line air filters are designed especially for vacuum applications as an economical alternative to our ILF Series. Choose from ten standard pipe sizes ranging from 2” to 14” and flow capacities ranging from 120 to 5,900 CFM. Two choices of filter element media—pleated paper or pleated felt—are available to suit your specific application.

Universal’s Filter Restriction Gauge provides a convenient, accurate means of monitoring filter pressure drop as the filter element becomes increasingly loaded with dirt. In-line air filters are standard with threaded connections for directly mounting the gauge. See p. 9.15 for a complete description.

Model	Part Number	P (nom.)	D	L	N	Y	C	K	Weight (est.)	Rated Cap. (CFM)
ILFV-2	34-D02-TT*	2	14	9.5	3.5	6.5	7	10	18	120
ILFV-2½	34-D25-TT*	2.5	14	9.5	3.5	6.5	7	10	19	190
ILFV-3	34-D03-TT*	3	14	9.5	3.5	6.5	7	10	20	275
ILFV-4	34-D04-TT*	4	14	9.5	3.5	6.5	7	10	21	500
ILFV-5	34-D05-AA*	5	18	12	3.5	7.75	10	12	50	750
ILFV-6	34-D06-AA*	6	18	20.5	3.5	12	10	12	65	1,100
ILFV-8	34-D08-AA*	8	24	13.25	3.5	8.25	11	15	90	2,200
ILFV-10	34-D10-AA*	10	24	22.75	3.5	13	11	15	125	3,000
ILFV-12	34-D12-AA*	12	30	17.25	3.5	10.25	15	18	160	4,300
ILFV-14	34-D14-AA*	14	30	30.75	3.5	17	15	18	205	5,900

All models have a .125” FNPT tap for installation of a gauge or manometer to monitor pressure drop. The C dimension is clearance required to remove elements. Non-ASME code construction is suitable for 15” Hg vacuum. Not applicable for pressure applications. Rated capacity is based upon flow velocity of approximately 5500 ft/min.

If pressure drop allowance permits, capacity may be increased by as much as 50%. Flange connections are drilled per ANSI standard for each size. Sizes 2” through 4” are standard with male pipe threaded inlet and outlet fitting (MNPT). Sizes 5” through 14” are standard with plate flanges drilled to ANSI standards (dashed lines on sketch).

Weight does not include filter elements. **Refer to page 14 for filter element details.**

\*Specify “P” at the end of part number for paper element or “F” for synthetic felt.



# Filter Elements

## ILF/ILFS Series

P (nom.)	Replacement Element Part Number		
	Paper	Felt	Wire Mesh
3	81-1063	81-1205	81-1038
4	81-1063	81-1205	81-1038
5	81-1063	81-1205	81-1038
6	81-0475	81-1207	81-1040
8	81-0475 (2)	81-1207 (2)	81-1040 (2)
10	81-1163	81-1209	81-1200
12	81-1163	81-1209	81-1200
14	81-1164	81-1210	81-1201
16	81-1164	81-1210	81-1201
18	81-1164	81-1210	81-1201

## ILFV Series

P (nom.)	Replacement Element Part Number		
	Paper	Felt	Wire Mesh
2	81-1063	81-1205	—
2½	81-1063	81-1205	—
3	81-1063	81-1205	—
4	81-1063	81-1205	—
5	81-0475	81-1207	—
6	81-0475 (2)	81-1207 (2)	—
8	81-1163	81-1209	—
10	81-1163 (2)	81-1209 (2)	—
12	81-1164	81-1210	—
14	81-1164 (2)	81-1210 (2)	—



81-0323

### Oil Free Adhesive

This is an oil-free product developed for use on viscous impingement type filters. It is a substitute for applications that do not permit oil wetting of the filter elements, such as oil-free compressors. Universal Oil-Free Adhesive is available in 13 oz. aerosol spray cans.



81-1234

### Filter Restriction Gauge

The Filter Restriction Gauge provides a convenient, accurate means of monitoring filter pressure drops as the filter element becomes increasingly loaded with dirt. Cartridge Filters and Filter silencers are standard with threaded connections for direct mounting of the gauge.





**UNIVERSAL**

*Acoustic & Emission Technologies*

®

## **GLOBAL HEADQUARTERS**

Universal  
1925 Highway 51/138  
P.O. Box 411  
Stoughton, WI 53589 USA  
Phone (608) 873-4272  
Fax (608) 873-4298  
[www.universalAET.com](http://www.universalAET.com)