



UNIVERSAL

Acoustic & Emission Technologies

Engine Exhaust Silencers

Technical Literature

Multi-Chamber Silencers

EN Series Silencers

∴ EN2/EN2Y, EN3/EN3Y Page 3

∴ EN4/EN4Y, EN5/EN5Y Page 4

Straight-Through Silencers

ET Series Silencers

∴ ET2, ET4 Page 5

ES Series Silencers

Spark Arresting Silencers

∴ ES2, ES3 Page 6

Accessories

∴ Flex Connectors, Flanges, Raincaps Page 7

∴ Mounting Attachments and Openings Page 8

*Universal AET retains the right to update this technical sheet without notice.
Please contact your Universal representative to verify the timelines of this technical literature sheet.*



General Information

Specialized Engine Exhaust Silencers

EN Series Silencers

Multi-Chamber Silencers

For the majority of engines and operating conditions, multi-chamber type silencers provide maximum noise attenuation within acceptable back pressure limits. Most naturally aspirated and supercharged engines need this type of silencer. Many turbocharged engines are best silenced with this design also. Factors which influence the choice of silencer design are explained on the following page.

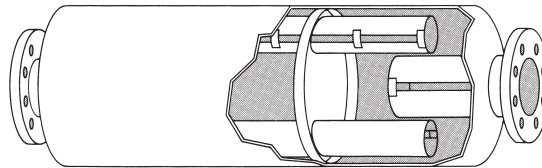

Multi-chamber exhaust silencers for most reciprocating engines.

ET Series Silencers

Straight-Through Silencers

Some engines require very low exhaust system back pressures for maximum performance. Many turbocharged engines and some naturally aspirated engines fall into this category. For these engines, straight-through, reactive silencers are available to provide adequate silencing while imposing negligible restriction on exhaust gas flow.

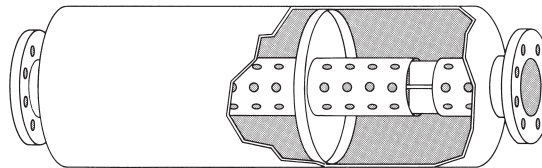

Straight-through exhaust silencers for engines which demand very low back pressures.

ES Series Silencers

Spark Arresting Silencers

Operating locations exist where fire hazards and safety codes require removal of sparks from exhaust gases. Universal's spark arrestor silencers are engineered to perform the dual function of spark arrestment and silencing for all internal combustion engines.

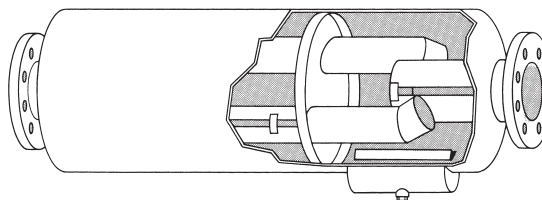

Spark arresting exhaust silencers for engines operating in high potential fire areas.



Sizing Information

Engine Exhaust Silencers

Universal's engine exhaust silencers are high quality, fully welded, reactive silencers designed to reduce exhaust noise on all types of internal combustion engines. Each engine and each operating location requires a unique combination of silencer properties. For this reason many

different silencer models are cataloged to cover most silencing problems. In cases where standard silencers will not meet a particular spec, these custom silencers will satisfy the application need.

Choosing the correct exhaust silencer for a given engine is an important although not difficult task. First of all, a degree of silencing is chosen that will satisfy the noise requirements unique to each engine and location. Secondly, the silencer size is selected to accommodate the specified volume of exhaust flow without imposing excessive back pressure.

Selection of Silencer Type (Grade)

Each silencer group described on pages 3–6 has a number of a series with different noise attenuation characteristics.

The series letter designation (e.g., EN2) indicates in relative terms the degree of noise attenuation; the higher the number, the greater the attenuation.

- 2 "Industrial" or "Commercial" grade
- 3 "Residential" grade
- 4 "Critical" grade
- 5 "Hospital" grade

The attenuation curves next to the tables on each page indicate the expected attenuation in dB by octave bands.

These curves are based upon "typical" applications. They will not necessarily define the precise insertion loss for any specific application since the insertion loss achieved may be influenced substantially by many factors, including engine size, type, speed, and unsilenced noise levels and frequency distribution.

Selection of Silencer Size

The open flow area within the silencer should be large enough to accommodate the maximum possible exhaust flow without exceeding the engine manufacturer's maximum allowable back pressure. Improperly sized silencers may cause loss of power or damage to the engine.

Data required:

- engine exhaust flow (CFM)
- exhaust temperature (°F)
- maximum back pressure (inches of water)

The following formulas enable the correct silencer size to be quickly determined.

1 Calculate gas velocity.

$$V = 4005 \sqrt{\frac{\Delta P}{c \left(\frac{530}{T + 460} \right)}}$$

- V = gas velocity
- ΔP = back pressure, inches of water
- c = silencer pressure drop coefficient (Table 1)
- T = exhaust gas temperature, °F

Note: Velocity should not exceed 15,000 ft/min regardless of the allowable back pressure.

2 Calculate required flow area.

$$\text{Flow Area Required (ft}^2\text{)} = \frac{\text{CFM}}{V}$$

3 From Table 2, select the silencer size which has a flow area equal to or greater than that calculated. The actual back pressure can be calculated as follows:

$$V_{\text{actual}} = \frac{\text{CFM}}{\text{silencer flow area}}$$

$$\Delta P = c \left(\frac{V_{\text{actual}}}{4005} \right)^2 \left(\frac{530}{T + 460} \right)$$

1 Pressure Drop Coefficients

Silencer Model	Pressure Drop Coeff. (C)
EN 2, 3, 4	4.2
EN5 (1"-10")	4.2
EN5 (12")	5.3
ET2	0.5
ET4	1.0
ES2, 3	4.2

2 Flow Area/Size

Flow Area (ft ²)	Diameter (in.)
0.0055	1
0.012	1.5
0.022	2
0.034	2.5
0.049	3
0.067	3.5
0.087	4
0.136	5
0.196	6
0.349	8
0.55	10
0.79	12
1.07	14
1.4	16
1.8	18
2.2	20
2.6	22
3.1	24
3.7	26
4.3	28
4.9	30
5.6	32
6.3	34
7.1	36
7.9	38
8.7	40
9.6	42
10.6	44
11.5	46
12.6	48
15.9	54
19.6	60



**EN2, EN3,
EN4, EN5 Series**

**EN2Y, EN3Y,
EN4Y, EN5Y Series**

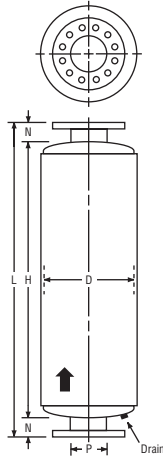

**End-In, End-Out
Design**

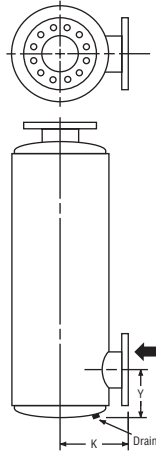

**Side-In, End-Out
Design**

EN Series

Multi-Chamber Silencers

EN2, EN3, and EN4 Series Engine Exhaust Silencers are heavy-duty, fully welded units constructed of carbon steel sheet and plate. Each silencer is equipped with flanged connections drilled to match 125/150 lb ANSI specifications. Exterior surfaces receive a coat of heat resistant paint.

For EN5 Series, 1"-3.5" are sizes equipped with standard male pipe thread connections. Sizes 4" and larger have flanged connections drilled to match 125/150 lb ANSI specifications.

The addition of "Y" in the model designation indicates a side inlet. Both configurations are fundamentally alike and performance is identical.

EN2 Size	Part Number	D	L	N	H	K	Y		Weight
							Min.	Max.	
4	19-104-AA	12	40	3	34	9	6	15	60
5	19-105-AA	14	46	3	40	10	6.5	19	70
6	19-106-AA	16	59	3	53	11	7.5	25	130
8	19-108-AA	20	61	3.5	54	13.5	9	25	190
10	19-110-AA	24	74	3.5	67	15.5	11	30	280
12	19-112-AA	28	75	3.5	68	17.5	12.5	30	420
14	19-114-AA	36	77	3.5	70	21.5	14.5	30	650
16	19-116-AA	36	113	3.5	106	21.5	15.5	40	900
18	19-118-AA	42	127	3.5	120	24.5	17.5	50	1,400
20	19-120-AA	48	130	4.5	121	28.5	19	55	1,600
22	19-122-AA	48	142	4.5	133	28.5	20	60	1,800
24	19-124-AA	54	156	4.5	147	31.5	22.5	70	2,500
26	19-126-AA	60	169	4.5	160	34.5	24.5	80	3,200
28	19-128-AA	60	181	4.5	172	34.5	25.5	80	3,400
30	19-130-AA	60	194	4.5	185	37.5	27	90	4,700

Note: Dimensions and weights are nominal and may vary slightly with production models. Request certified drawings of specific models for exact dimensions.

EN3 Size	Part Number	D	L	N	H	K	Y		Weight
							Min.	Max.	
4	20-104-AA	14	47	3	41	10	6	20	70
5	20-105-AA	16	59	3	53	11	7	24	130
6	20-106-AA	18	60	3	54	12	8	24	150
8	20-108-AA	22	73	3.5	66	14.5	9.5	32	250
10	20-110-AA	26	86	3.5	79	16.5	11	36	390
12	20-112-AA	30	111	3.5	104	18.5	12.5	52	700
14	20-114-AA	36	113	3.5	106	21.5	14.5	52	900
16	20-116-AA	42	127	3.5	120	24.5	16.5	62	1,200
18	20-118-AA	48	129	3.5	122	27.5	18	62	1,450
20	20-120-AA	48	142	4.5	133	28.5	19	62	1,600
22	20-122-AA	54	156	4.5	147	31.5	21.5	72	2,300
24	20-124-AA	60	181	4.5	172	34.5	23.5	82	3,050
26	20-126-AA	66	195	4.5	186	37.5	25	92	4,400
28	20-128-AA	72	209	4.5	200	40.5	27	103	5,000
30	20-130-AA	72	220	4.5	211	40.5	28	103	5,400

Note: Dimensions and weights are nominal and may vary slightly with production models. Request certified drawings of specific models for exact dimensions.

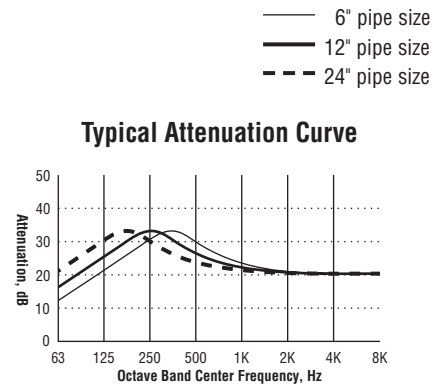
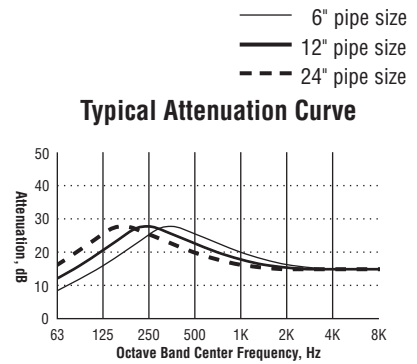

EN Series

Multi-Chamber Silencers

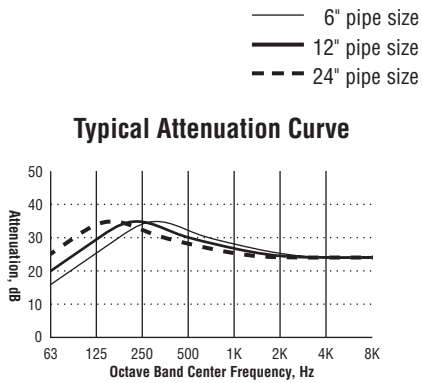

EN4

Size	Part Number	D	L	N	H	K	Y		Weight
							Min.	Max.	
4	21-104-AA	14	59	3	53	10	6	26	85
5	21-105-AA	16	71	3	65	11	7	33	120
6	21-106-AA	18	72	3	66	12	8	33	170
8	21-108-AA	24	93	3.5	86	15.5	9.5	42	400
10	21-110-AA	28	111	3.5	104	17.5	11.5	52	550
12	21-112-AA	36	114	3.5	107	21.5	14	52	950
14	21-114-AA	36	125	3.5	118	21.5	14.5	63	1,100
16	21-116-AA	42	139	3.5	132	24.5	16.5	63	1,350
18	21-118-AA	48	176	3.5	169	27.5	18	86	2,200
20	21-120-AA	48	190	4.5	181	28.5	19	96	2,500
22	21-122-AA	54	192	4.5	183	31.5	21.5	96	3,000
24	21-124-AA	60	217	4.5	208	34.5	23.5	107	3,800
26	21-126-AA	66	231	4.5	222	37.5	25	117	5,850
28	21-128-AA	72	257	4.5	248	40.5	27	128	6,750
30	21-130-AA	72	280	4.5	271	40.5	28	139	7,500

Note: Dimensions and weights are nominal and may vary slightly with production models. Request certified drawings of specific models for exact dimensions.

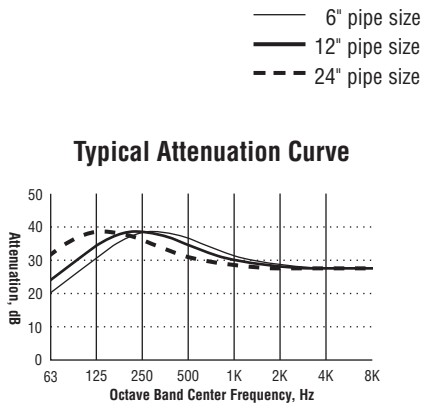

EN5

Size	Part Number	D	L	N	H	K	Y		Weight
							Min.	Max.	
1	22-101-AA	6	25.5	3	19.5	6	2.5	9	10
1.5	22-115-AA	8	27	3	21	7	3.5	9	20
2	22-102-AA	10	34	3	28	8	4.5	13	30
2.5	22-125-AA	12	40	3	34	9	5	16	50
3	22-103-AA	12	46	3	40	9	5	18	60
3.5	22-135-AA	14	59	3	53	10	5.5	24	90
4	22-104-AA	16	71	3	65	11	6	33	110
5	22-105-AA	18	72	3	66	12	8	33	160
6	22-106-AA	22	85	3	79	14	9	40	300
8	22-108-AA	26	111	3.5	104	16.5	10	50	480
10	22-110-AA	30	136	3.5	129	18.5	11.5	65	800
12	22-112-AA	36	138	3.5	131	21.5	14	46	1,050
14	22-114-AA	36	168	3.5	161	21.5	14.5	64	1,200
16	22-116-AA	42	193	3.5	186	24.5	16.5	75	1,750
18	22-118-AA	48	213	3.5	206	27.5	18	85	2,750
20	22-120-AA	48	227	4.5	218	28.5	19	85	3,050
22	22-122-AA	54	240	4.5	231	31.5	21.5	96	3,550
24	22-124-AA	60	278	4.5	269	34.5	23.5	106	5,100
26	22-126-AA	66	292	4.5	283	37.5	25	115	6,500
28	22-128-AA	72	329	4.5	320	40.5	27	128	7,600
30	22-130-AA	72	352	4.5	343	40.5	28	139	8,300

Note: Dimensions and weights are nominal and may vary slightly with production models. Request certified drawings of specific models for exact dimensions.



ET2, ET4 Series

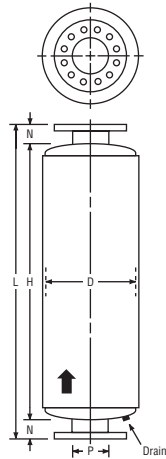

ET Series

Straight-Through Silencers

ET2 and ET4 Series Engine Exhaust Silencers are heavy-duty, fully welded units constructed of carbon steel sheet and plate. Each silencer is equipped with flanged connections drilled to match 125/150 lb ANSI specifications. Exterior surfaces receive a coat of heat resistant paint.

Due to low back pressure requirements, no side inlet configuration is cataloged. In some special cases side inlets may be designed on application.

ET2

Size	Part Number	N	D	L	H	Weight
4	29-104-AA	3	12	40	34	50
5	29-105-AA	3	14	46	40	80
6	29-106-AA	3	16	59	53	150
8	29-108-AA	3.5	20	61	54	230
10	29-110-AA	3.5	24	74	67	300
12	29-112-AA	3.5	28	75	68	420
14	29-114-AA	3.5	36	77	70	650
16	29-116-AA	3.5	36	113	106	900
18	29-118-AA	3.5	42	127	120	1,300
20	29-120-AA	4.5	48	130	121	1,500
22	29-122-AA	4.5	48	142	133	1,850
24	29-124-AA	4.5	54	156	147	2,550
26	29-126-AA	4.5	60	169	160	3,200
28	29-128-AA	4.5	60	181	172	3,400
30	29-130-AA	4.5	66	194	185	4,650

Note: Dimensions and weights are nominal and may vary slightly with production models. Request certified drawings of specific models for exact dimensions.

ET4

Size	Part Number	N	D	L	H	Weight
4	30-104-AA	3	14	59	53	80
5	30-105-AA	3	16	71	65	110
6	30-106-AA	3	18	72	66	160
8	30-108-AA	3.5	24	93	86	400
10	30-110-AA	3.5	28	111	104	550
12	30-112-AA	3.5	36	114	107	950
14	30-114-AA	3.5	36	125	118	1,100
16	30-116-AA	3.5	42	139	132	1,400
18	30-118-AA	3.5	48	176	169	2,300
20	30-120-AA	4.5	48	190	181	2,500
22	30-122-AA	4.5	54	192	183	2,800
24	30-124-AA	4.5	60	217	208	4,050
26	30-126-AA	4.5	66	231	222	5,500
28	30-128-AA	4.5	72	257	248	6,500
30	30-130-AA	4.5	72	280	271	7,100

Note: Dimensions and weights are nominal and may vary slightly with production models. Request certified drawings of specific models for exact dimensions.

— 6" pipe size
 — 12" pipe size
 - - - 24" pipe size

Typical Attenuation Curve

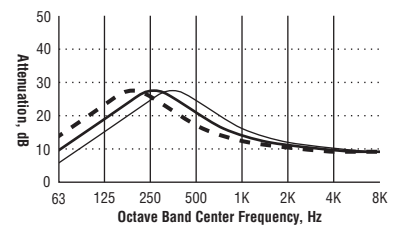

— 6" pipe size
 — 12" pipe size
 - - - 24" pipe size

Typical Attenuation Curve

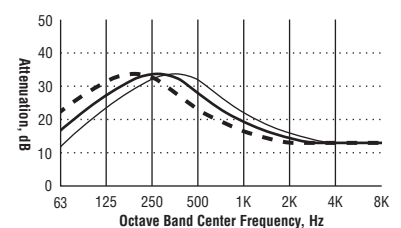

ES Series

Spark Arrestor Silencers

ES2 and ES3 Series spark arresting silencers are heavy-duty, fully welded units constructed of carbon steel sheet and plate. Each silencer is equipped with flanged connections drilled to match 125/150 lb ANSI specifications. Exterior surfaces receive a coat of heat resistant paint.

Large capacity spark traps are provided on each unit which can be easily opened for periodic cleaning. Side inlet configurations will be designed on application.

ES2 and ES3 Series may be mounted vertically or horizontally.

ES2, ES3 Series

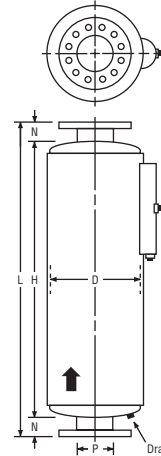

End-In, End-Out Design

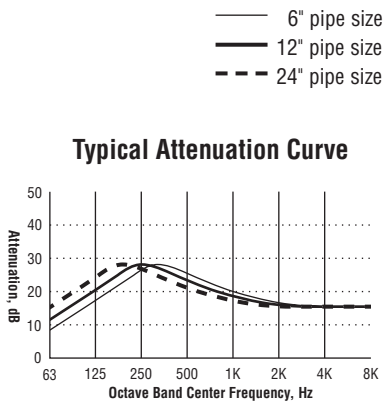

ES2

Size	Part Number	N	D	L	H	Weight
4	25-104-AA	3	12	40	34	50
5	25-105-AA	3	14	46	40	70
6	25-106-AA	3	16	59	53	110
8	25-108-AA	3.5	20	61	54	170
10	25-110-AA	3.5	24	74	67	290
12	25-112-AA	3.5	28	75	68	430
14	25-114-AA	3.5	36	77	70	600
16	25-116-AA	3.5	36	113	106	850
18	25-118-AA	3.5	42	127	120	1,350
20	25-120-AA	4.5	48	130	121	1,550
22	25-122-AA	4.5	48	142	133	1,700
24	25-124-AA	4.5	54	156	147	2,400
26	25-126-AA	4.5	60	169	160	3,050
28	25-128-AA	4.5	60	181	172	3,200
30	25-130-AA	4.5	66	194	185	4,600

Note: Dimensions and weights are nominal and may vary slightly with production models. Request certified drawings of specific models for exact dimensions.

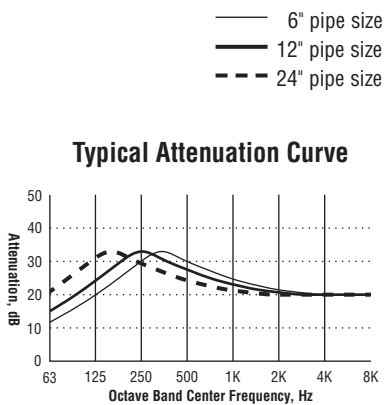

ES3

Size	Part Number	N	D	L	H	Weight
4	26-104-AA	3	14	47	41	70
5	26-105-AA	3	16	59	53	130
6	26-106-AA	3	18	60	54	160
8	26-108-AA	3.5	22	73	66	240
10	26-110-AA	3.5	26	86	79	350
12	26-112-AA	3.5	30	111	104	600
14	26-114-AA	3.5	36	113	106	950
16	26-116-AA	3.5	42	127	120	1,200
18	26-118-AA	3.5	48	129	122	1,500
20	26-120-AA	4.5	48	142	133	1,650
22	26-122-AA	4.5	54	156	147	2,350
24	26-124-AA	4.5	60	181	172	3,100
26	26-126-AA	4.5	66	195	186	4,500
28	26-128-AA	4.5	72	209	200	5,100
30	26-130-AA	4.5	72	220	211	5,600

Note: Dimensions and weights are nominal and may vary slightly with production models. Request certified drawings of specific models for exact dimensions.

Accessories

Engine Exhaust Silencers

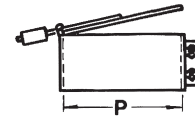
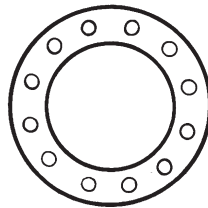
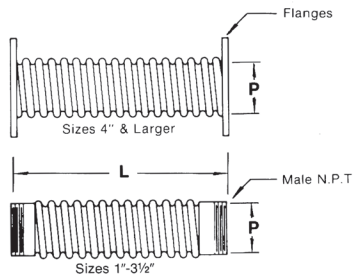

Flex Connectors

P (Size)	L (Nominal)	Weight
1	18	4
1.5	18	6
2	18	7
2.5	18	9
3	18	10
3.5	18	12
4	18	14
5	18	17
6	18	24
8	18	36
10	18	62
12	18	69
14	18	90
16	18	110
18	18	130

Flex Connectors are recommended for engine exhaust applications to compensate for thermal expansion and vibration (but not misalignment). Flexible material is type 321 stainless steel, suitable for temperatures to 1200°F. Flanges and pipe fittings are mild steel. Sizes 1"–3.5" are standard with male NPT, larger sizes are equipped with flanges drilled to 125/150 lb ANSI.

Companion Flange Set

Pipe Size	Weight
4	7
5	10
6	13
8	16
10	30
12	35
14	45
16	55
18	65
20	73
22	88
24	95
26	130
28	150
30	160

Each Companion Flange Set includes one mild steel welding flange drilled to match 125/150 lb ANSI, one gasket and one set of bolts and nuts. Cast iron threaded flanges and stainless steel flanges are available and will be quoted on request. Single and double reducing flanges are also available.

Raincaps

Part Number	P (Fits Pipe Size)	Weight
80-1061	1	.5
80-1062	1.5	.5
80-1063	2	1
80-1064	2.5	1
80-1065	3	1
80-1066	3.5	1.5
80-1067	4	2
80-1068	5	2
80-1034	6	5.5
80-1035	8	8
80-1036	10	11
80-1037	12	14
80-1038	14	22
80-1039	16	26
80-1040	18	30
80-1041	20	34
80-1042	22	36

Raincaps prevent rain, snow, and dust from entering the exhaust system. Non-corrosive bushings insure positive opening. All sizes are standard in mild steel with high temperature paint. Sizes 8"–22" are also available in stainless steel—quoted by request and equipped with adjustable counterweights.



Accessories

Engine Exhaust Silencers

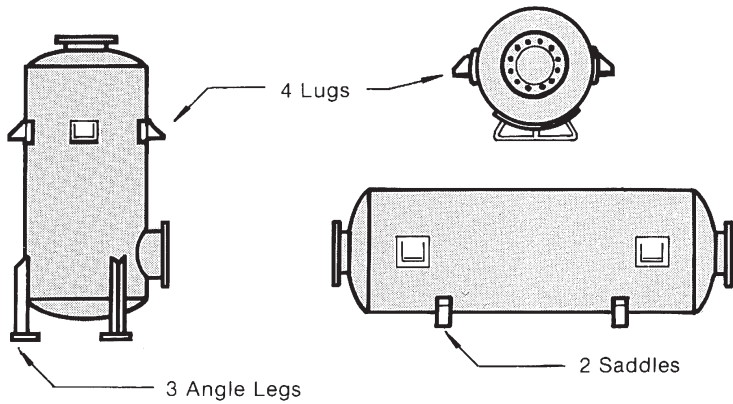

Mounting Attachments

Mounting Attachments are welded in place on the silencer shell to facilitate installation. Standard and variable dimensions are available.

Inspection Openings

Part	Inspection Opening Size (Oval)	Weight
80-1019	3 × 4	4
80-1020	4 × 6	6
80-1021	6 × 8	12
80-1025	8 × 10	20

Inspection Openings have removable covers to provide access to silencer internals for inspection or cleaning. Usually one opening per silencer chamber is recommended.

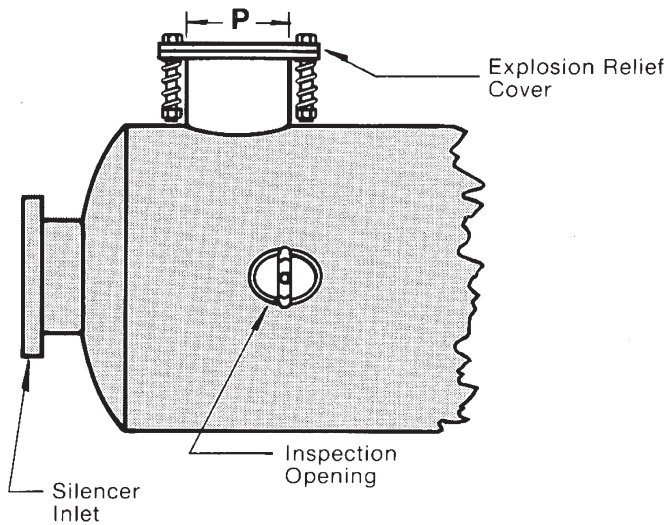

Explosion Relief Cover

Part	P-Relief Cover Size	Weight
80-0622	8	30
80-1059	12	50
80-1060	16	95
80-1053	20	130
80-1405	26	210

Explosion Relief Covers are designed to open at 5 PSI to protect the silencer shell against rupture in case of backfire or explosion of residual gases within exhaust system. One unit in first chamber of silencer is adequate.